

# **BERNINA®**



**Service manual**

**BERNINA 1008 / 1020 / 1030**

This manual remains the property of our company, reproduction, publication or information to a third party without our written approval is forbidden.

FRITZ GEGAUF LTD.,  
Manufactures of BERNINA Sewing-Machines  
Steckborn (TG) Switzerland

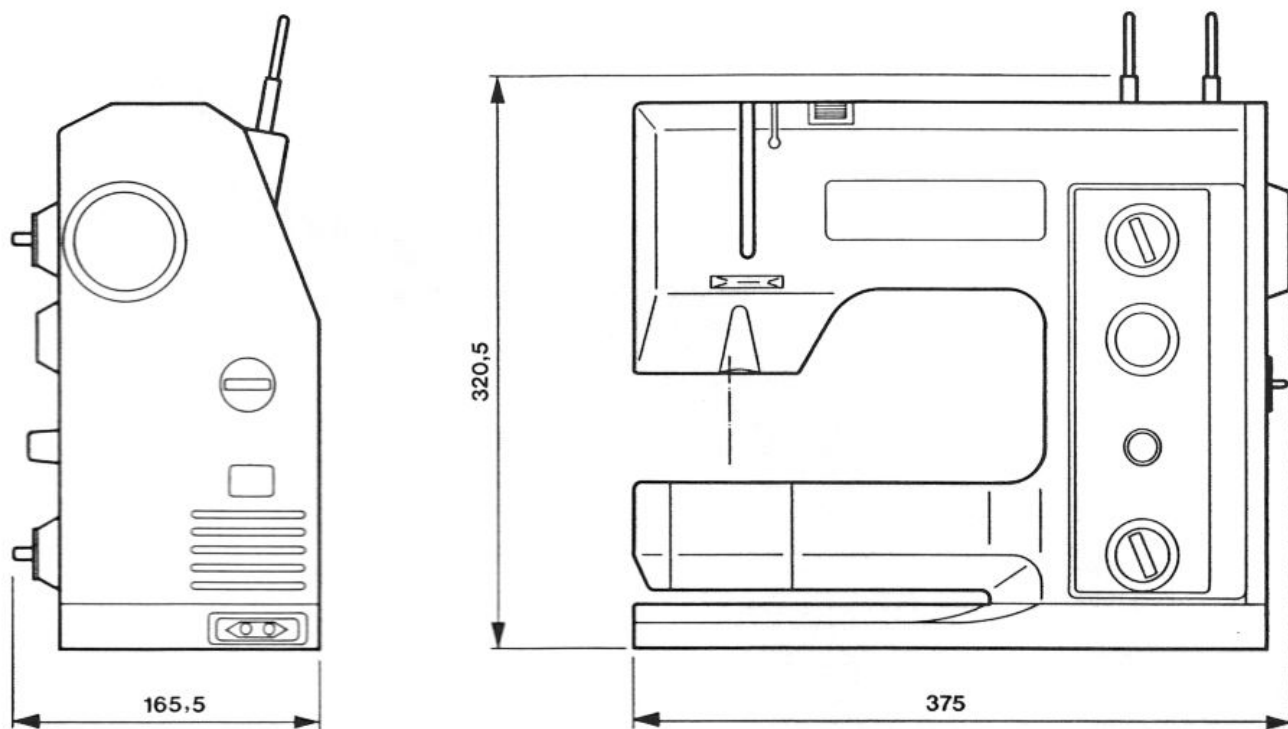

## Contents

	Page		Page
1. Adjustment of models 1030–1020	4	40. Stitch length stop position	30
2. Technical data	4	41. Zero position of feed control crank	30
3. Special D.C. mains adaptor	5	42. Zero stitch link position	31
4. Changing the light bulbs	6	43. Forward-reverse feed equalization (honeycomb stitch)	32
5. Removing belt and chassis cover	6	44. Tracer position with reverse feed switched off.	33
6. Removing base and needle plate	7	45. Density of the bar tack	33
7. Dismantling chassis and motor support	8	46. Cutting space and bead widths	34
8. The needle	11	47. Needle stop	47
9. Adjustment of the bobbin winding device	12	48. Basting device and automatic long stitch (needle bar guide)	47
10. Switching of the bobbin winding motor	12	49. Basic setting of latch release pin	36
11. Height of presser foot	13	50. Instant of decoupling	37
12. Presser foot fixation	13	51. Cushioner position	37
13. Height of darning foot	14	52. Knee lifter lever	38
14. Presser foot crosswise to sewing direction	14	53. Lowering the feed-dog	39
15. Adjustment of thread take-up lever	15	54. Lower thread tension	39
16. Adjustment of feed-dog in the machine in relation to the throat plate	15	55. Upper thread tension (basic adjustment with and without control weight)	40
17. Height of feed-dog	16	56. Removing the needle drive assembly, complete	41
18. Tensioning of the belt (hook drive)	16	57. Mounting the needle drive assembly, complete	43
19. Tensioning of the belt (motor drive)	17	58. Tracer adjustment on the long stitch cam	44
20. Rest position of the needle	17	59. Provisional tracer lift (needle operation)	44
21. Lateral needle distribution L.M.R.	18	60. Tracer distribution on the cams	45
22. Hook and driver (thread passage play)	18	61. Display, stitch pattern extended	45
23. Position of driver in hook race	19	62. Removing the carrier	46
24. Radial play of driver (minimal correction)	19	63. Mounting the carrier	47
25. Radial play of driver (large correction)	20	64. Special gauge for basic carrier adjustment	48
26. Hook adjustment (loop lift)	20	65. Height of feed-dog (carrier)	49
27. Height of needle	22	66. Depth limiter	50
28. Needle – hook distance	22	Feed-dog	50
29. Position of thread guide plate	23	67. Hook drive (carrier)	50
30. Throat plate adjustment	24	68. Axial play in stitch length crank	51
31. Feed synchronisation (green zone)	24	69. Zero position of the stitch length crank	51
32. Reverse feed synchronisation (red zone)	25	70. Removing the head frame	52
33. Cam timings for feed cam group and upper shaft	26	71. Installing the head frame	52
34. Wormwheel clearance	26	72. Notes on adjustments of be made after removing or reinstalling certain parts	53
35. Zig-zag stitch distribution	27		
36. Lateral motion of needle (arc)	28		
37. Tracer lift (needle control)	28		
38. Control of scale for stitch position, stitch width, stitch length, and presser foot	29		
39. Stitch length adjustment knob	30		

---

	Page
<b>73 Electrical and electronic chapter</b>	<b>55</b>
73.0 Print L/R 1030/1020, 220V	56
73.1 Print L/R 1030/1020, 110V	57
73.2	58
<b>Diagnosing Manual</b>	<b>59</b>
74.0 Important warnings	59
<b>Testing</b>	
Test 1 – Mains cable (cable retractor)	61
Test 2 – Sewing light, bobbin winding motor, main motor print L-1030	62
Test 3 – Foot control connection	63
Test 4 – Foot control unit	64
Test 5 – Light housing cplt.	65
<b>Electronic Function Test</b>	<b>66</b>



## 1 Adjustment of models 1030–1020

The adjustment instructions are intended to help with small repairs and adjustments. The instructions lay no claim to completeness. They are not suitable for a complete assembly or disassembly procedure.

*Important:* To enable the work described to be performed, the sewing machine must be in good mechanical and electrical condition. (Running smoothly, properly oiled and all plugs in position).

When the adjustments are done in the correct order, the machine is guaranteed to sew impeccably.

### Removal of covers

*Warning:* The electronic components operate with dangerous voltages. The mains plug must be withdrawn before making any adjustments to the machine. Wait at least 30 seconds afterwards (capacitor discharge).

## 2 Technical data for BERNINA models 1030–1020

	1030	1020		1030	1020
Stitch length: forwards max. 5 mm	×	×	Working space 105+195 mm	×	×
reverse max. 2.5 mm	×	×	Overall length 375 mm	×	×
Stitch width max. 5.5 mm continuous	×	×	Overall width 167 mm	×	×
Needle system 130/705 H	×	×	Overall height 350 mm	×	×
Adjusting needle 130/705 H/TCN			Motor 90 W	×	×
Hook system BERNINA CB =			No. of stitches per minute		
Central bobbin	×	×	min. – max. 120–1050 min <sup>-1</sup>	×	×
Lowest point of needle bar = 0°	×	×	reduced min. – max.		
Presser foot height = 7.5 mm	×	×	120–600 min <sup>-1</sup>	×	×
Darning foot: minimum height = 0.5 mm	×	×	Sewing light: bulbs 2x6 V/4 W	×	×
Automatic long stitch = 10 mm 2:1	×		Weight 9.8 kg		
<b>Features and functions</b>	<b>1030</b>	<b>1020</b>		<b>1030–1020</b>	
Needle position 5	×	×	Practical stitches with reverse feed	8	7
Zig-zag and stitch length infinitely adjustable	×	×	Decorative stitches without reverse feed	3	1
Display of setting in window	×	×	Decorative stitches with reverse feed	5	4
Presser foot display	×	×	Number of stitch patterns	26	22
Upper needle stop (general)	×	×	Decorative stitch pattern repeat 36	×	×
Needle positioning up/down with foot control	×	×	Main switch	×	×
Pattern start with mechanical pattern repeat display	×	×	Speed reduction switch combined with main switch	×	×
Buttonhole 6-step	×	×	Separate light switch	×	×
Automatic long stitch	×	×	Bobbin winder with separate motor	×	×
Practical stitches without reverse feed	10	10			

## 3 D.C. mains adaptor 4200 for models 1130 and 1030

The 4200 mains adaptor supplies power for the sewing light and bobbin winder motor. The main motor runs on 30V DC, so that the entire machine is under low voltage only.

This mains adaptor is useful when the reinforcement plate with print L-1030 is removed for adjustment work.

### Operating the mains adaptor

- Remove the belt and chassis cover (sections 5 and 7).
- Remove the chassis with print L-1030 (section 7).
- Connect plugs P151, P153, P154 to the print.
- Connect the adaptor to the mains.

When the power is switched on the display will light up and the adaptor is ready for use.

Switch on the main motor and it should run slowly; put the switch in the "off" position and the motor should stop immediately.

The adaptor print with cable can be plugged in. Use only adaptor for model 1030.

There is a 400 mA fuse on the back of the adaptor.

*Note:* Since this adaptor only supplies the main motor with 30V DC, the max. speed of the machine will be approx. 120 R.P.M.

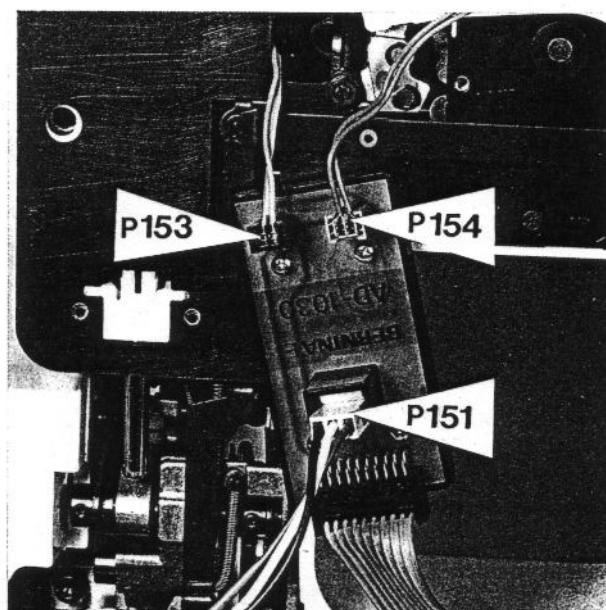
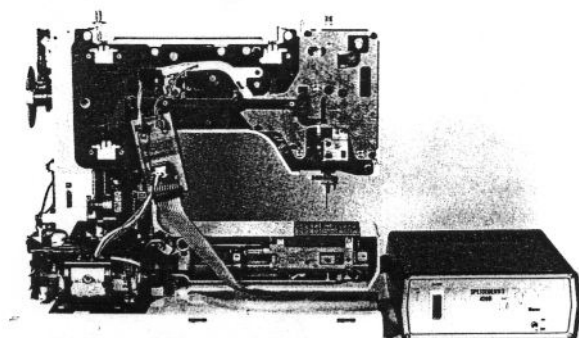

## 4 Changing the bulb

There are two low voltage lamps both 6V, 4W. One bulb is situated at the front, left, the other behind the presser bar, right.

To change the bulbs use special tool (10) (bayonet socket).

To change the bulb at the rear, remove diffuser (11).

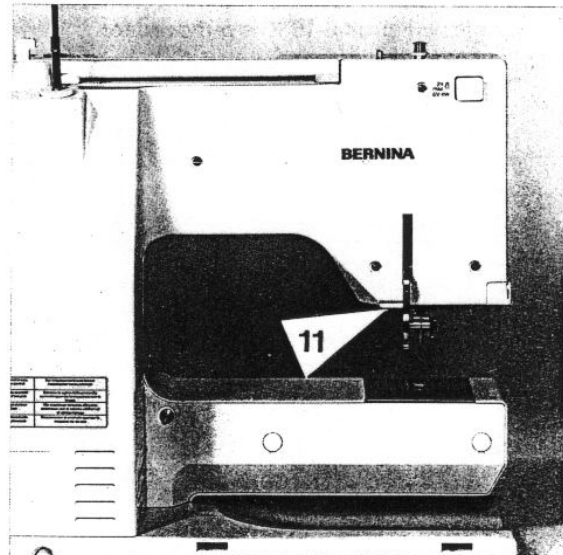
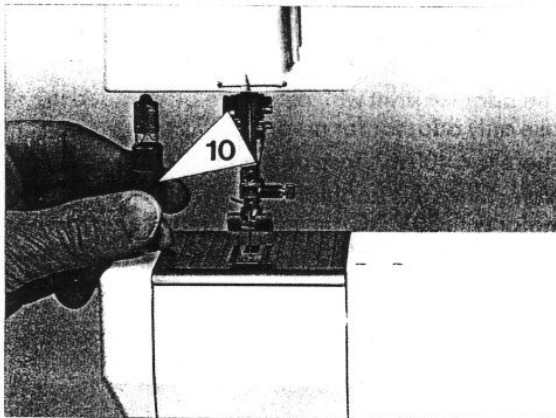

## 5 Removing belt cover

- Remove cover plate on handwheel with small screw-driver.
- Release handwheel screw and remove handwheel.
- Remove knob (12) main switch.

- Loosen and remove two screw (13).
- Remove the belt cover.

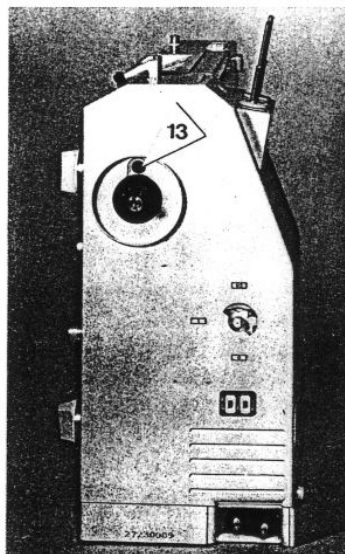
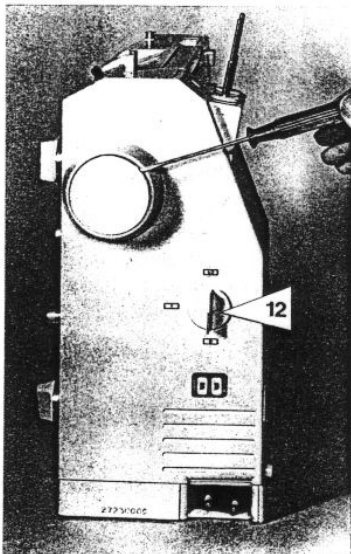

## Removing chassis cover

- Remove six screws (14).
- Place the lifting lever in upward position and remove chassis cover.

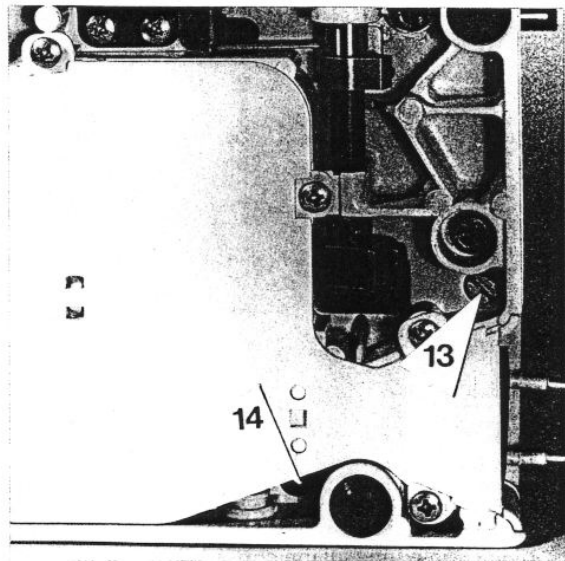
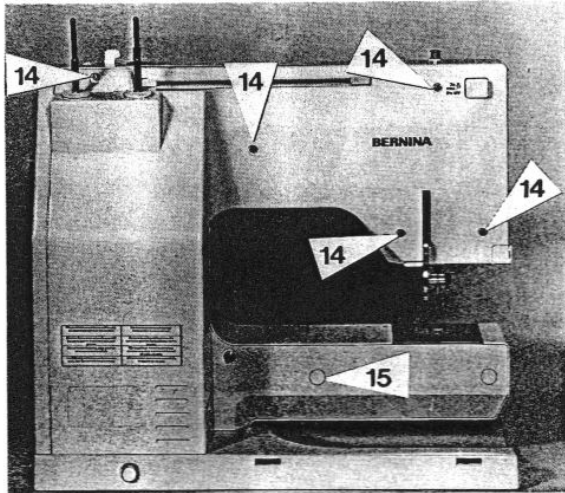

## 6 Removing base cover

- Remove cap covers (15).
- Remove three screws (16) and base cover.

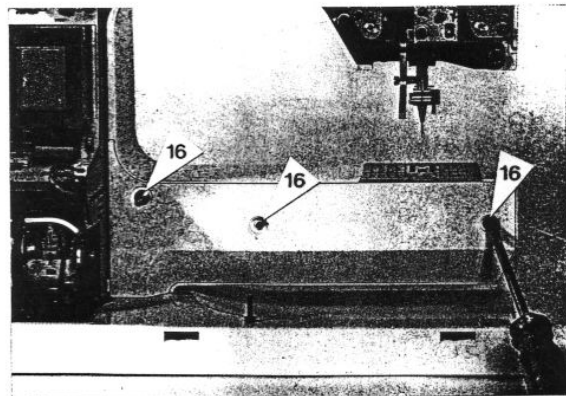
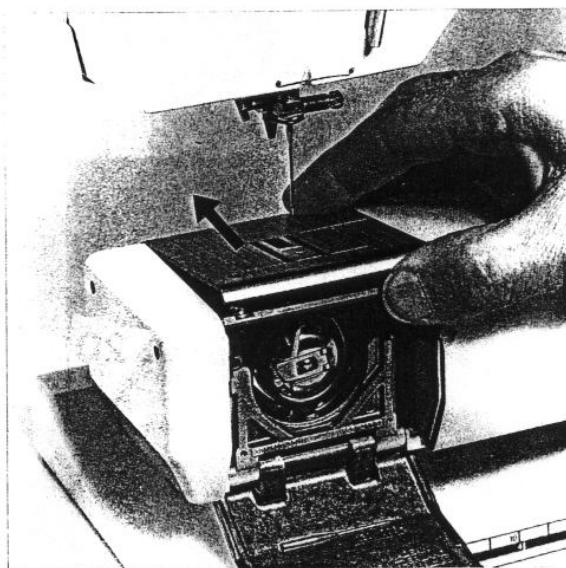

## Removing needle plate

- Lower feed-dog.
- Open hinged cover.
- Lightly lift front of the needle plate and remove by sliding away from you.

## 7 Complete removal of chassis with "L" PCB 1030–1020

- Disconnect wires to "L" PCB 1030–1020 (P150/P151/P153/P154/P156)

- Remove two screws (17).
- Press lightly with a screwdriver on the snap action lock (18) situated on the chassis (19) and at the same time tilt the chassis in the direction indicated by the arrow.
- Press the right-hand hinge (20) slightly outwards and remove chassis (19).

Note: During reassembly make sure that the needle stop lever is correctly inserted in the appropriate slot on the chassis.

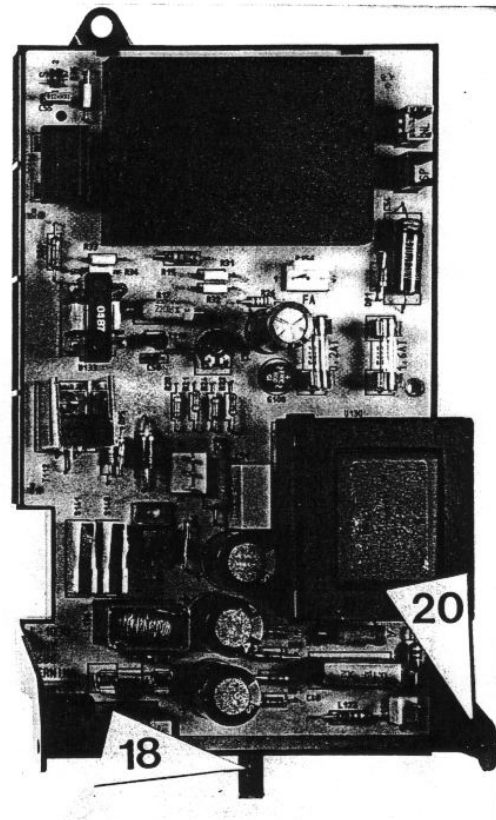
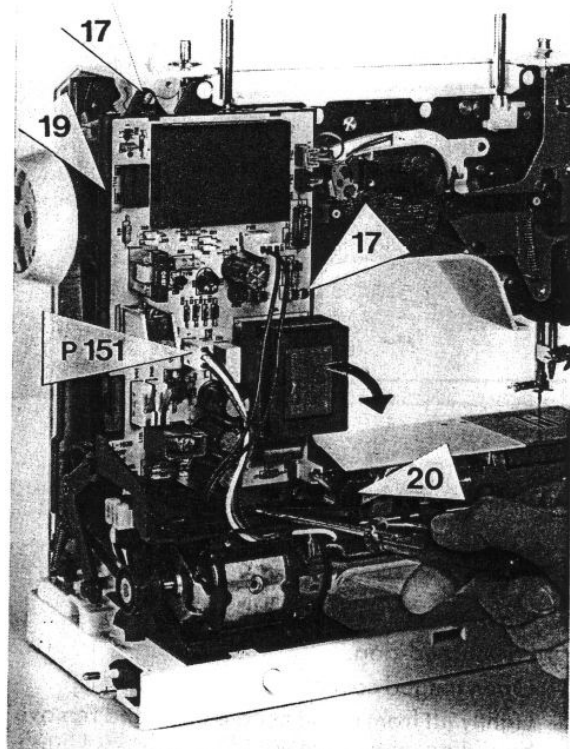
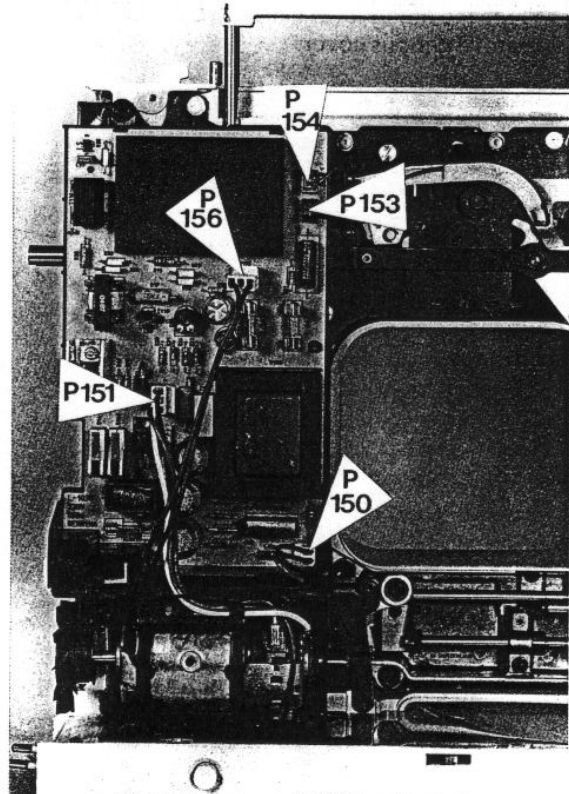

## Dismantling motor support

- Remove cover from cable channel (21). This is to the right of the motor support (22) and is removed by pushing to the right (22).
- Remove screws (23) from motor support.
- Release the drive belt.
- Remove motor support.

To assemble reverse the procedure.

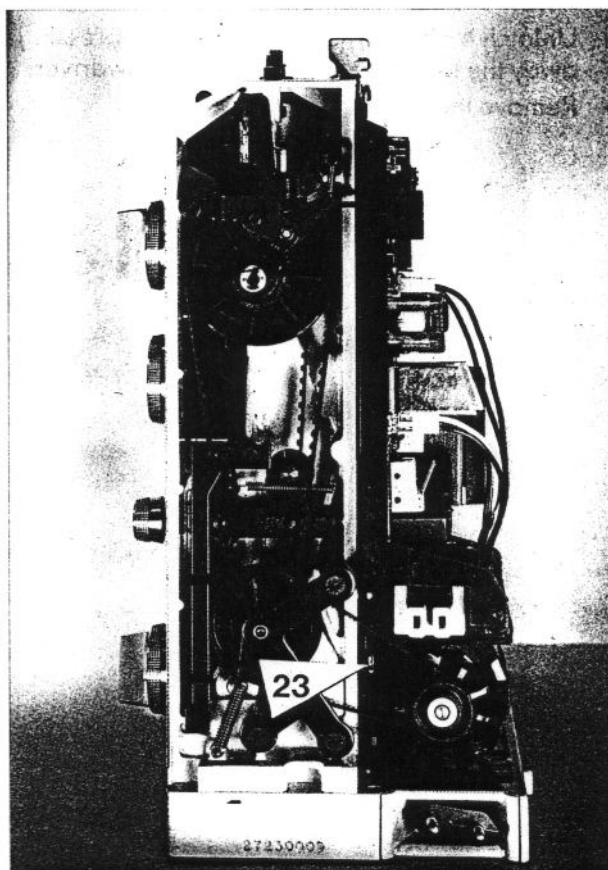
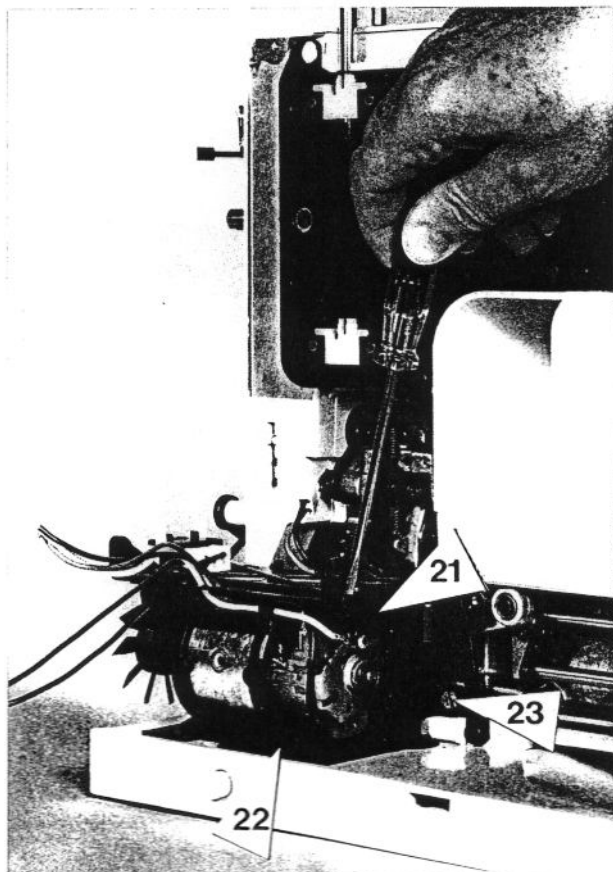



## Removing the motor

- Disconnect the mains plug
- Unplug the foot control
- Remove the handwheel
- Remove the main switch
- Remove the belt cover
- Remove the chassis cover
- Disconnect plug P151
- Remove the toothed belt
- Unlatch the motor holding bracket by pressing away the top of the casing with a screwdriver.
- Remove the motor

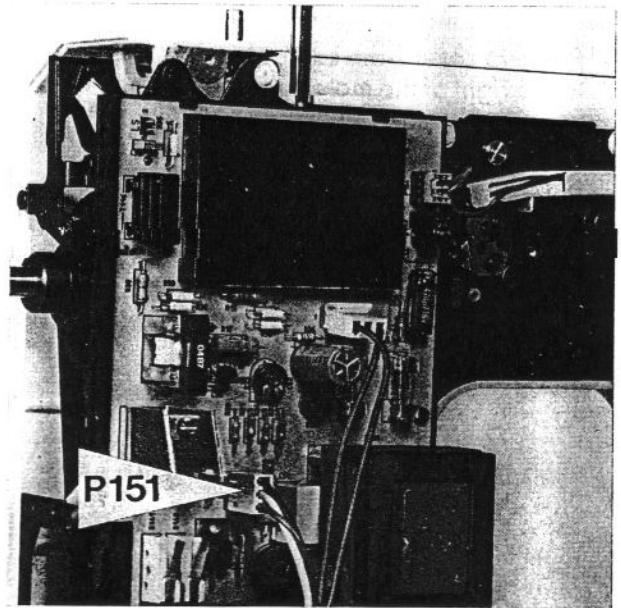

## 8 The needle

The needle is one of the most important items of sewing equipment. Its function is to pierce the material and take the upper thread to the hook for linking with the lower thread and to form the loop for acceptance by the hook.

The loops is formed after the needle has pierced the material and reached its lowest point. The thread is drawn tight and lies in a long groove at the front. At the rear the thread lies in a short groove which is higher up between the needle stem and the hole pierced in the fabric. When the needle rises slightly, the so-called «loop lift», the loop is produced at the eye of the needle on the short groove side, which the tip of the hook can enter, as a result of the friction between the work and the needle stem where the thread is retarded. Basically, the sewing machine needle has the following features:

- a) The shaft, for securing the needle in the needle bar,
- b) the stem with a long groove for guiding the thread and forming the loop,
- c) the scarf,
- d) the eye of the needle,
- e) the point of the needle,
- f) the needle length.

BERNINA uses the 130/705H needle system with scarf for models 1030–1020.

The needle size is measured in millimeters. Needle size "100" means a needle stem thickness = 1 mm or Nm80 (Needle mm) = 0,8 mm dia.

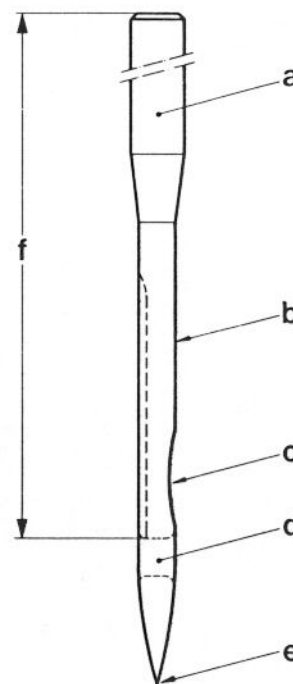

The needle must be firmly secured with the knurled screw on the needle holder. Tighten this screw with the special screwdriver.

*Important:* Always use an "Nm80" TCN needle for all adjustments unless otherwise stated. Check the needle before every adjustment to the machine. It must be absolutely straight.



## 9 Checking the bobbin winding device

The device should be wound evenly with pre-tension, the bobbin should be correctly filled.



*Correction:* For one-sided winding

- Connect the bobbin winding device to the special D.C. adaptor (see section 3).
- Slightly loosen fixing screw (26) of support (27).
- With eccentric key (28) adjust the support plate (27) accordingly left or right.
- Tighten fixing screw (26).

*Corrections:* When filling the bobbin

### **Bobbin insufficiently filled**

- Move tensioning spring (29) upwards.

### **Bobbin too full**

- Move tensioning spring (29) downwards.

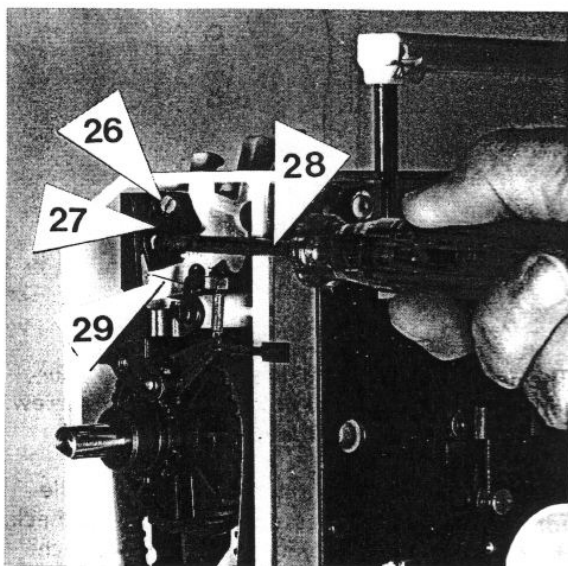

## 10 Checking the switching off of motor to bobbin winding device

The motor should only switch off when release lever (30) springs back.

### **Correction**

- Bend contact element on switch (31) accordingly. For this operation the bobbin winding device doesn't need removing (see sketch).

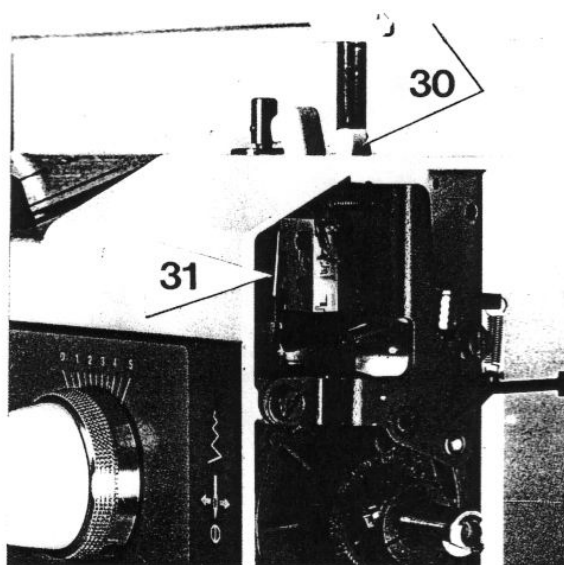

## 11 Checking the presser foot height

- Lower feed-dog.
- Raise lifter lever.
- Using gauge (33) 7,5 mm check the height.

### Correction

- Loosen screw (32) on the presser foot bar guide.
- Using the cone on the presser foot, place this on the gauge (33) 7,5 mm. (Note that it is parallel to the marked line).
- Press down the presser foot bar by hand. (Note darning lever position).
- Tighten screw (32).

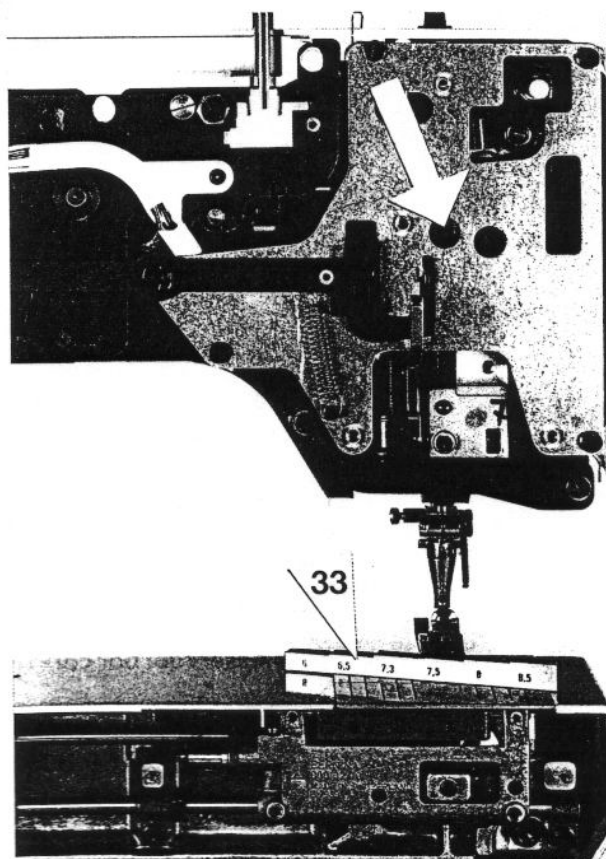
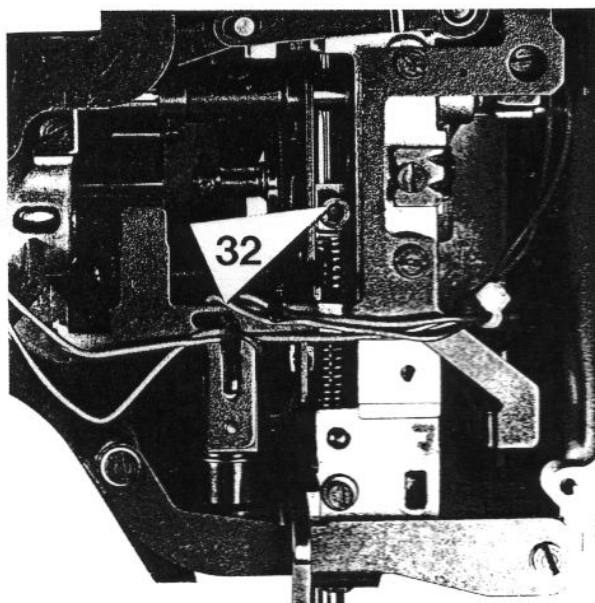

## 12 Checking presser foot fixation and its height

- Tension pin (54) should be one third to half the way up tension lever (55). The presser foot sole (56) must be parallel with the markings on the needle plate.

### Correction

- Loosen screw (57) on clamp (58).
- Adjust the height of clamp (58) until the correct tension position is reached. Align the presser foot sole with the markings on the stitch plate.
- Tighten screw (57).

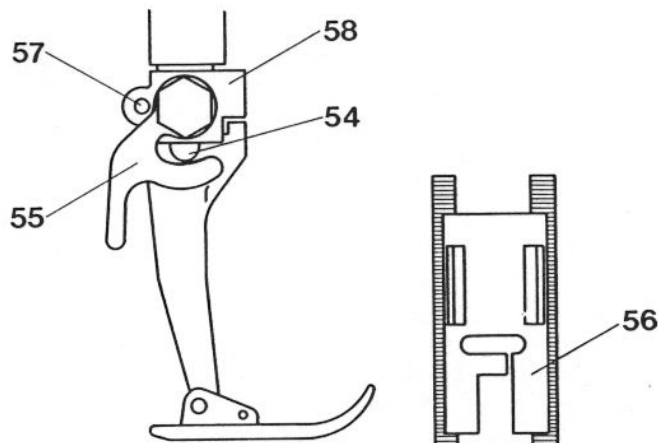

## 13 Checking the darning foot height

- Remove presser foot.
- Fit darning foot.
- Lower feed-dog.
- Turn the handwheel until the presser foot bar has reached its lowest position.
- Using feeler gauge (36) 0,5 mm check the distance between the needle plate and the darning foot sole.

### Correction

- Position balance piece (37), by using a 4 mm pin (38) placed against the head frame shaft (39).
- Loosen screw (40) of the presser foot bar carrier (41).
- Position the presser foot bar to the prescribed height.
- Press the presser foot bar carrier (41) on the eccentric (42). (Note its position.)
- Tighten screw (40).

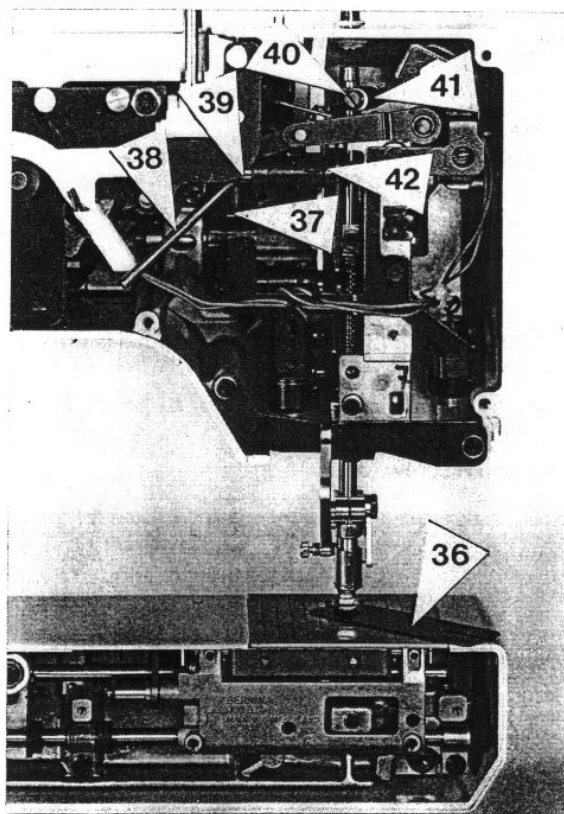

## 14 Presser foot crosswise to sewing direction

### Checking the position of presser foot crosswise to sewing direction

The presser foot sole must be evenly distributed sideways of the feed-dog slit.

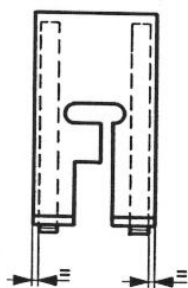

### Correction

- Remove rigidity plate (44). Remove 4 screws the circlip, and knielifter lever).
- Loosen both screws (45) from securing strap (46), on head frame.
- Slightly loosen the screws of the two clamps (47) enough to allow the head frame to slide freely. Also ensure that shaft (39) is well guided in the prism.
- Release setting collars (48) and (49) of the take-up lever link (50).
- Slide the head frame into the prescribed position.
- Tighten screws (47) of the clamps.
- Tighten screws (45) of securing strap (46).

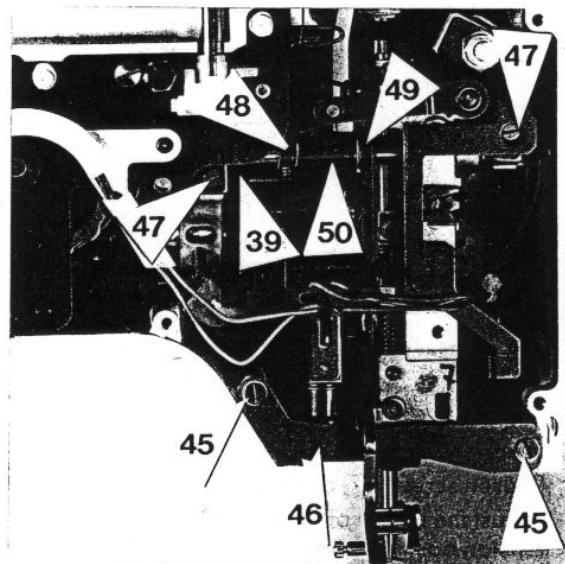

## 15 Adjustment of the thread take-up lever

### Correction

- Place thread take-up lever and guide (50) against the crank.
- Position securing collars (49) and (48).
- Tighten screws.

Note: Check smoothness of running.

### Checking

After this adjustment has been done, the position of the thread take-up lever in the frame slit should not be more than plus/minus 4/10 mm from centre.

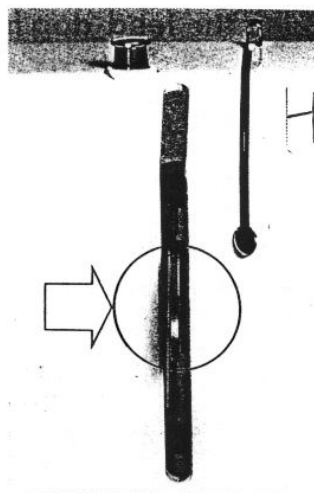

## 16 Adjustment of feed-dog in the machine

### Checking the feed-dog position in the needle plate

- Set feed dog to sewing.
- The feed-dog must be equidistant from each side of the needle plate.

### Correction

It is assumed that for this adjustment, the basic adjustment for the feed-dog height and sideways position has been done with the special gauge (60).

- Loosen the hook drive belt (section 18).
- Loosen carrier fixing screws (59) until the carrier (53) can be moved sideways.
- Position carrier (53) in the correct place.
- Lightly tighten carrier fixing screws (59).

Warning: Sideways adjustment to the feed-dog position should not be attempted with the feed-dog advance fork (52).

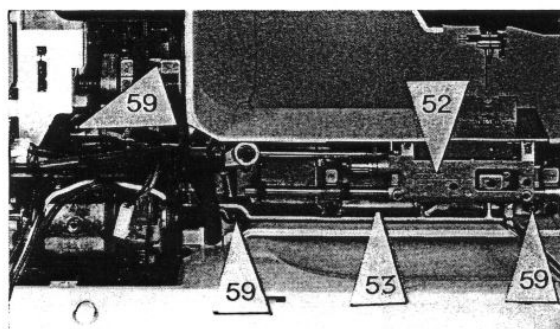
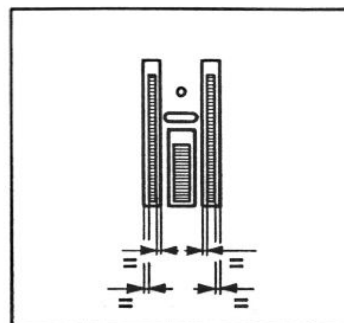

## 17 Checking the feed-dog height

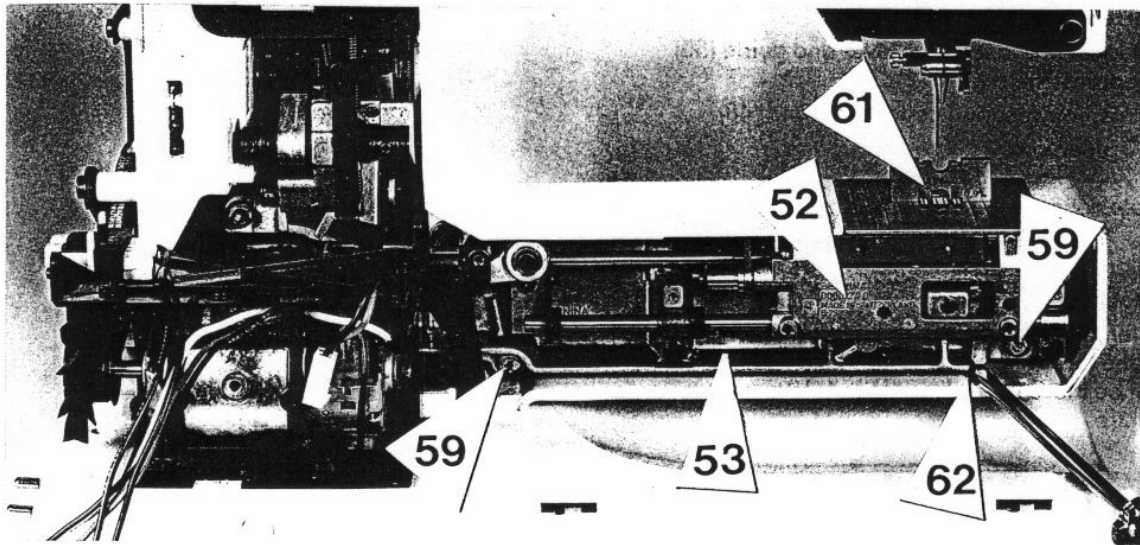

At their highest point, the tips of the feed-dog teeth should be 0,9 mm to max. 1,0 mm above the needle plate. (Check with gauge [61]).

*Note:* When adjusting it is an advantage to make a feed motion.

After this adjustment is made it is important to check the distance between needle and hook (section 28).

### Correction

- Slightly loosen carrier fixing screws (59).
- Using the end of a screw driver at point (62) move the carrier until the height 0,9–1,0 mm is attained (watch that it stays parallel).
- Tighten screws (59).



## 18 Tension of the belt for the hook drive

The belt tension is achieved automatically between the tension roller and the tension spring.

- Slightly loosen the two fixing screws (63) from the tension roller holder (64).
- Turn the handwheel forwards and backwards.
- Tighten the two fixing screws (63).

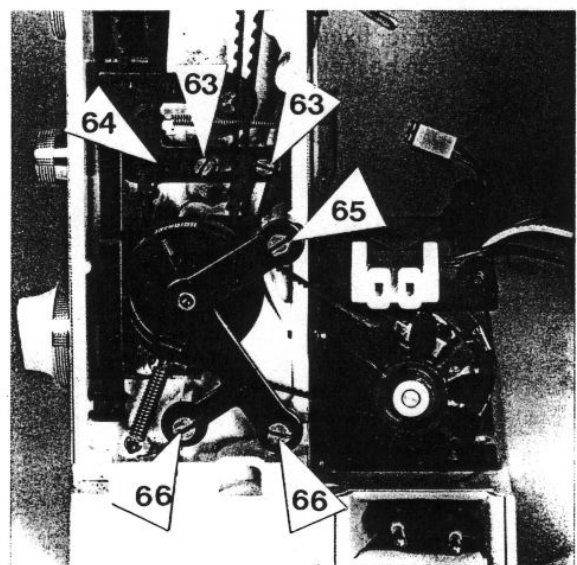

## 19 Tensioning the drive belt

The drive belt is automatically tensioned by means of a tensioning spring.

- Slightly loosen fixing screws (65) and (66). Turn the handwheel forwards and backwards.
- Tighten screws (65) and (66).

## 20 Rest position of needle

### Checking the rest position of needle

- Set the L.M.R. knob to the central position.
- Set the stitch width knob to 0 (straight stitch).
- Move the cam operating lever (67) quickly to and fro by hand. The needle should not make any sideways motion.

### Correction

- Loosen screw (68).
- Insert a 2,5 mm allen key (long) in the stop bore (69) and press to the left or right, at the same time moving the cam operating lever (67) to and fro by hand.  
The needle should not make any sideways motion.
- Tighten screw (68).

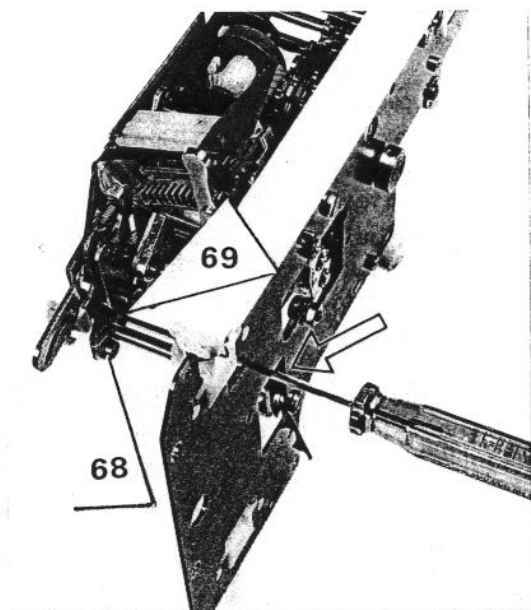
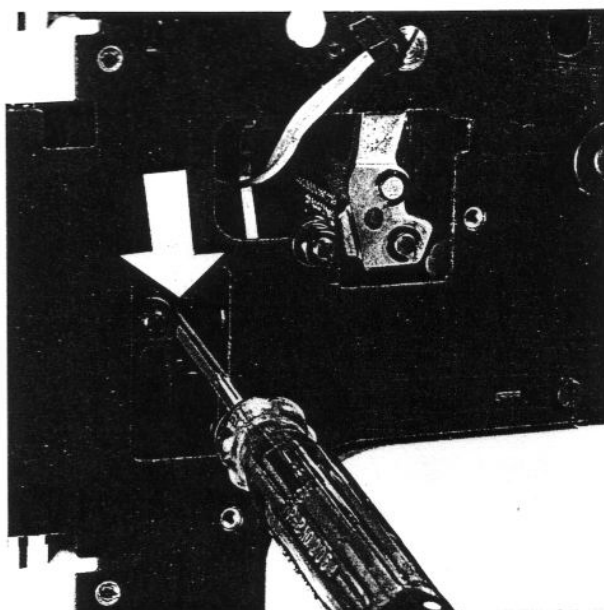
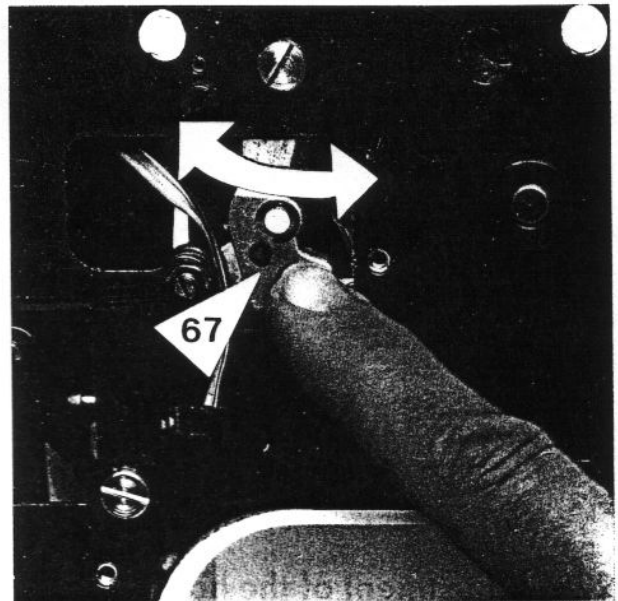



## 21 Needle distribution L.C.R. (Left, Centre, Right)

### Checking the needle distribution L.C.R.

- Insert needle No. 90 (inspected). The needle should be situated in the center of the stitch hole (section 30), as seen in the material feed direction.
- Move the L.C.R. knob to the left and right, observing whether the left-hand and right-hand needle penetration points are equidistant from the edges of the stitch hole.

### Correction

- Loosen the 2,5 mm screw (71) on the link rod (72).
- Set the needle bar in the correct position by hand.
- Tighten screw (71).

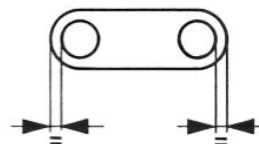
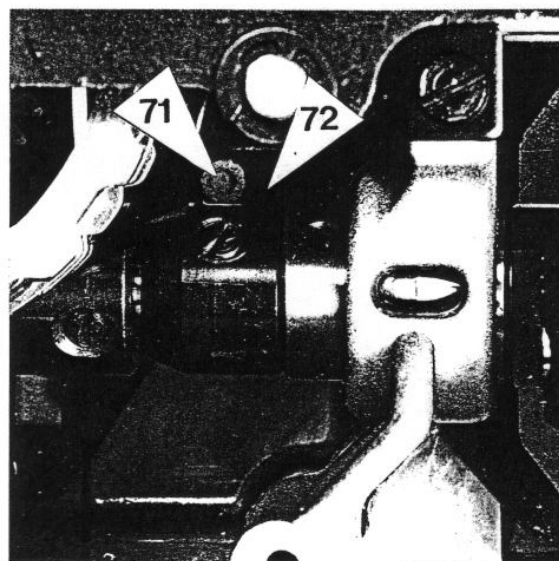

## 22 Adjustment of the hook

(CB-hook = Central Bobbin)

When adjusting the hook a straight needle must be used! (T.C.N.)

### Checking the thread passage

- a) There must be a play of 0,3 mm between hook (90) and hook drive (89) for the thread passage. Check with feeler gauge (91).
- b) The clearance between the thread guide cam (88) and the thread slot (87) on the hook race ring must also be 0,3 mm.

### Correction

If the spacing is too large or too small, the short stem of the hook driver (89) should be set with special tool (92).

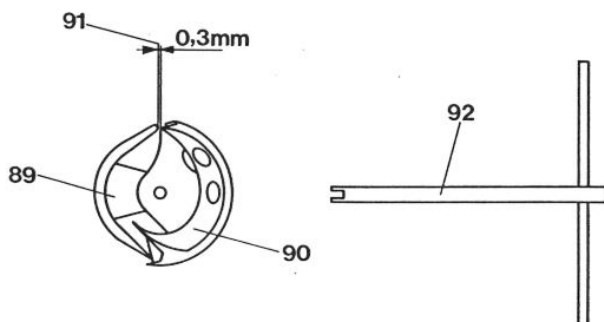
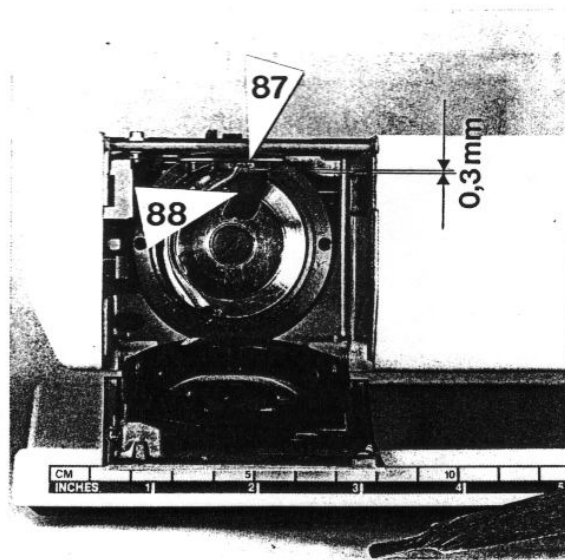

## 23 Checking the position of driver in hook race

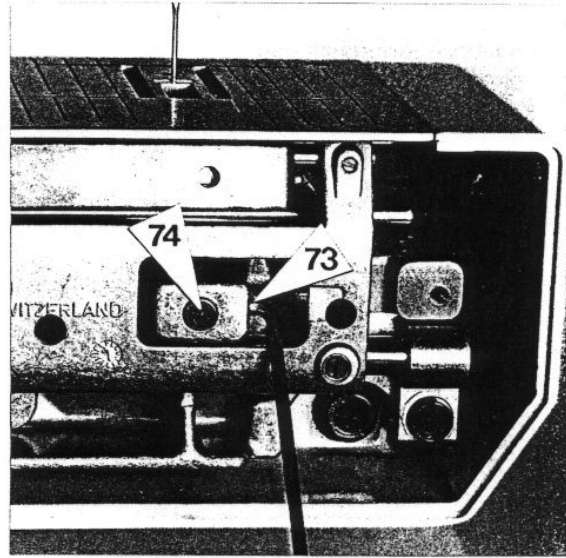
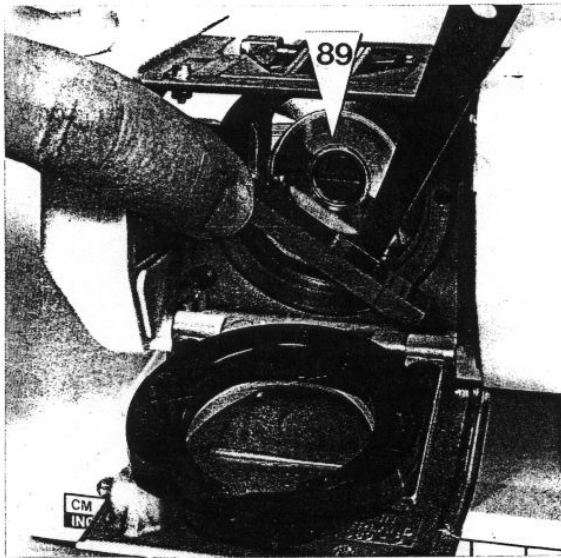

The hook driver (89) should be 0,1–0,15 mm behind the front edge of the hook race.

### Correction

- Loosen allen screw 2 mm (73) of the driver shaft (74).

- Push the complete driver (89) into the prescribed position.
- Re-tighten allen screw 2 mm (73) (being careful that it sits on the flat).

## 24 Checking radial play of the driver

- Bring the rack to its furthest right-hand position.
- By radial movement of the hook driver (89), check the play between the rack and the pinion.
- The driver (89) should have no radial play.

- Tighten screw (75) on the rack carrier (76).
- Check smoothness of running. (For large corrections see section [25]).

### Note for small corrections

- Loosen fixing screw (75) of the rack carrier (76).
- By radially turning rack (77) take out the play.

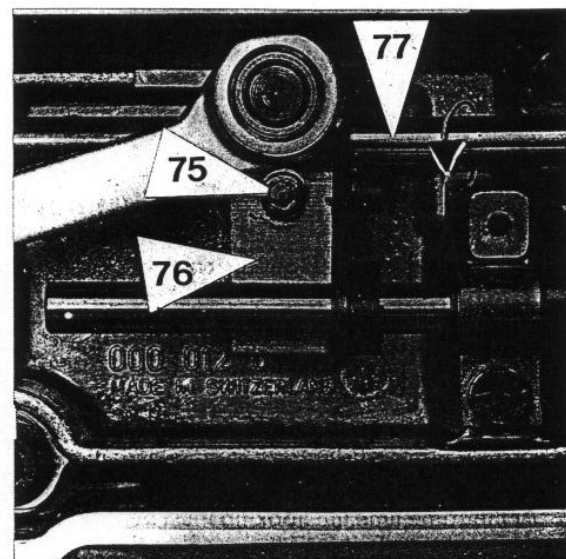
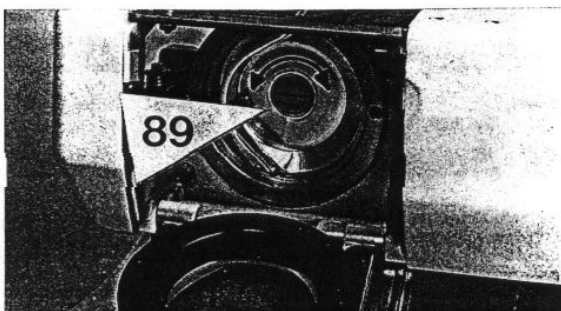



## 25 Adjustment of play between rack and toothed gear

- Disengage tension springs (80).
- Remove bearing fixing screw (81) of feed-dog advance shaft (82).
- Remove feed-dog advance shaft (82), feed-dog advance fork (52) and the complete feed-dog support.
- Loosen nut (83) (push feed-dog lifter cam to [84] the side).
- Loosen fixing screw (85) of the rear rack bearing.

- Slightly loosen screw (86) of the front rack bearing.
- By sliding the front rack bearing (in the height), the play between the rack and the pinion can be adjusted.
- Tighten screw (86) (front bearing).
- Tighten nut (83).
- Tighten screw (85) (rear bearing).

*Important:* Smooth running of the rack through the axial bearing should be observed.

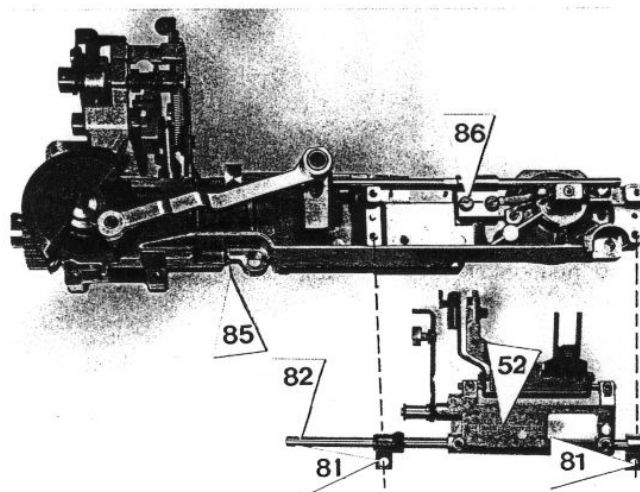
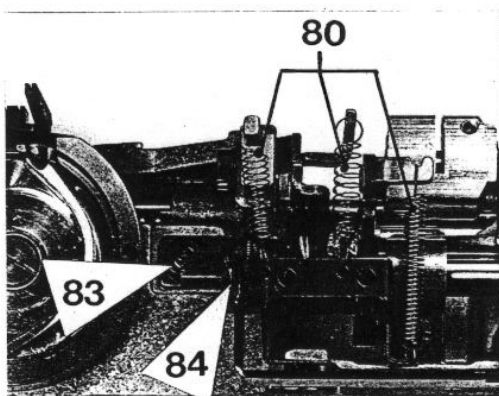

- Assemble and secure feed-dog advance shaft (82) with bearing and screw (81), feed-dog advance fork and complete feed-dog support (check feed-dog advance shaft for smoothness of running).
- Place the sliding block in the stitch length crank.
- Attach tension spring (80).
- Adjust depth limit with screw (79) (section [66]).

## 26 Checking the hook adjustment and loop lift

Carry out this work without the complete electrical chassis.

- Set the L.M.R. knob to the right.
- Pin the balance piece (93) of the needle drive, and turn the handwheel in the direction of rotation as far as the stop (39).
- The hook drive crank (94) should be in line with the marked point on the carrier (53).
- At the same time the hook tip must be flush with the right-hand edge of the needle.

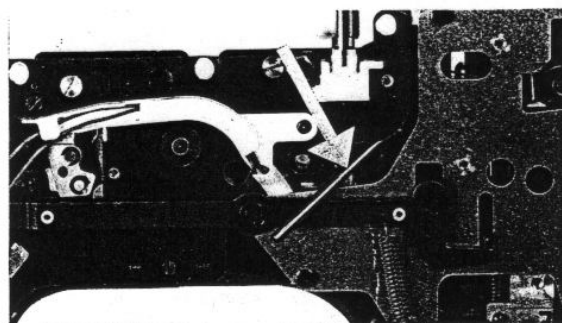

### Correcting the hook drive crank

- Dismantle the stepped pulley.
- Pin the feed operating cam (96) with 4 mm pin (38) (first bore in direction of rotation).
- Loosen screw (97) on the handwheel flange.

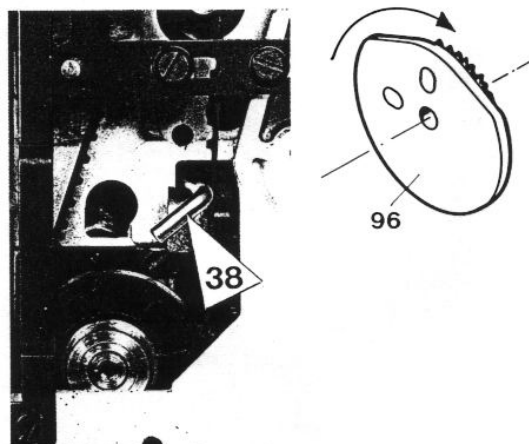
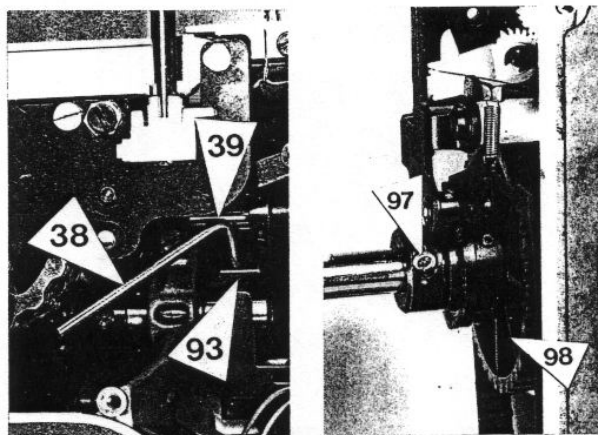

- Pin the balance piece (93) of the needle drive with 4 mm dowel (38), and turn the handwheel in the direction of rotation as far as the stop (39) on the headframe shaft.
- Turn the hook drive cam (94) until the marked points are in line (see illustration).
- Tighten screw (97).
- There must be a gap of at least 1 mm between the belt pulley (98) and the rear shaft bearing.

Note: Only small corrections are possible.

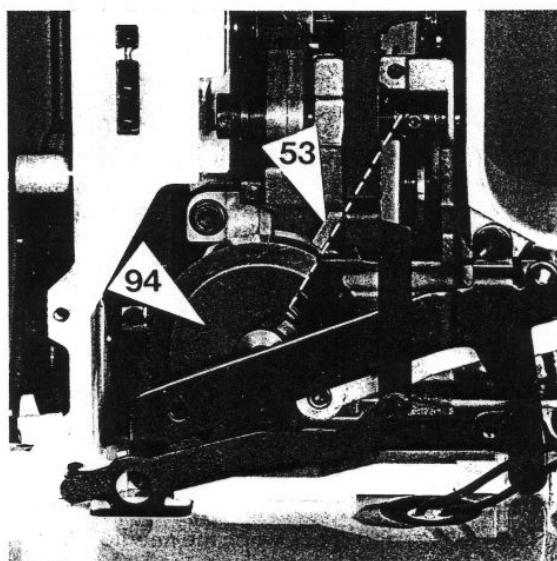

### Correction needle – hook tip

- Turn the L.M.R. knob to the right.
- Loosen screw (75) on the rack carrier (76).
- Adjust the rack (77) until the hook tip is flush with the right-hand needle edge.

- Tighten screw (75).
- Remove the two 4 mm pins (38).

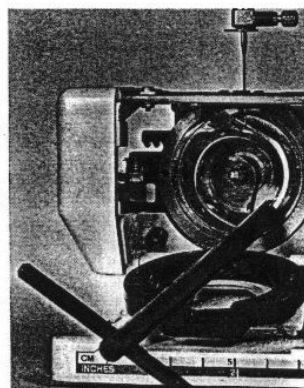
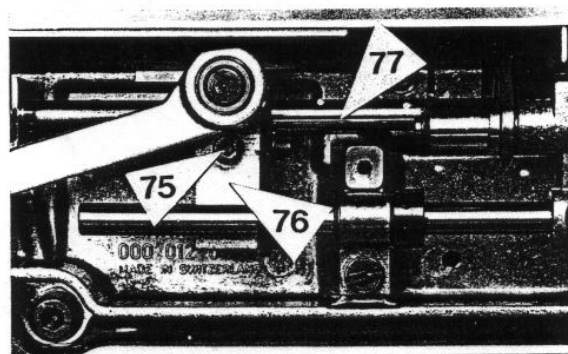

## 27 Checking the needle height

- Position the needle to the right.
- Position the hook tip flush with the right-hand edge of the needle.
- The lower edge of the hook tip should now be 0,2 mm above the upper edge of the eye of the needle.

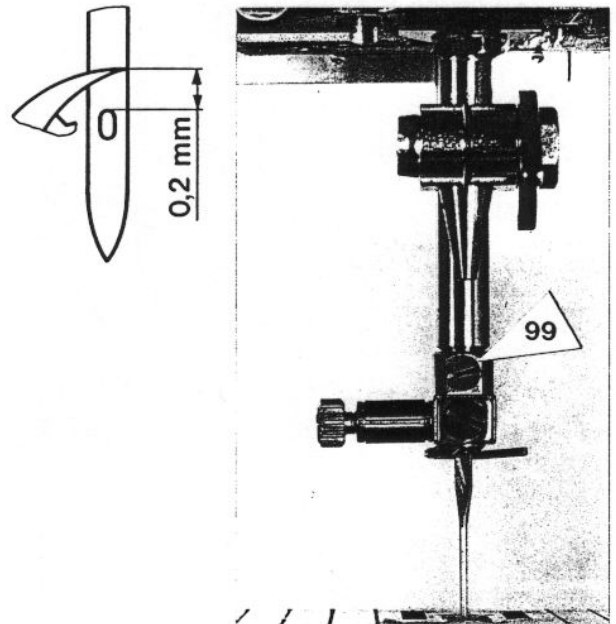

### Correction

The stop screw (99) must be replaced when necessary. It is available in various diameters.

Part. No.		
- 203 508 53	= screw diameter	2,40 mm
- 203 509 53	= screw diameter	1,45 mm
- 203 510 63	= screw diameter	1,95 mm
- 203 511 83	= screw diameter	2,85 mm

## 28 Checking the needle-hook distance without needle plate

- Only adjust and check when the needle is positioned in the middle.
- The lateral distance between the needle and hook in the scarf should be 0,01 – 0,05 mm.
- A greater distance can lead to skipped stitches.
- A lesser distance could damage the hook tip.

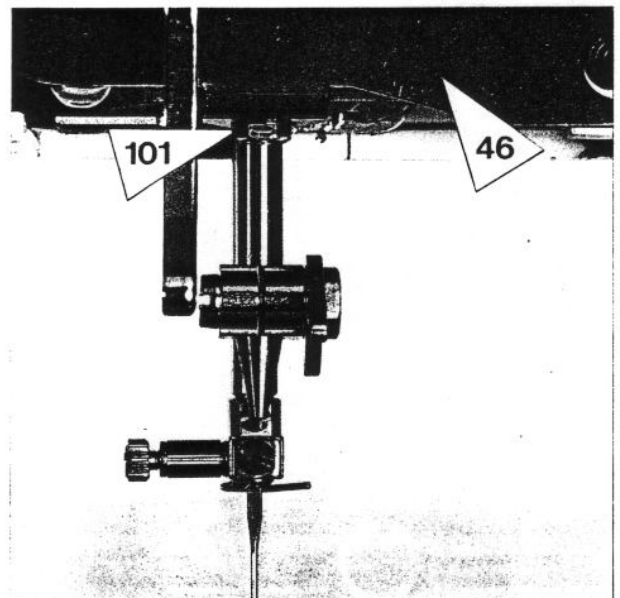
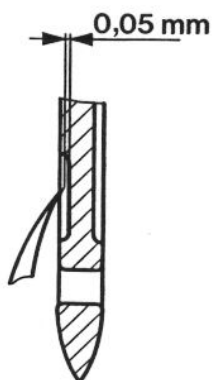

### Correction without needle plate

- Very slightly loosen clamps (47) of the head frame (100) so that it can be moved, but the shaft (39) in the prism is still well guided.
- Lightly loosen hexagon head screw 6 mm (101) on the securing strap (46).
- Set needle to the hook tip at 0,01–0,05 mm.
- Tighten screw (101) and clamp securing screws (47).

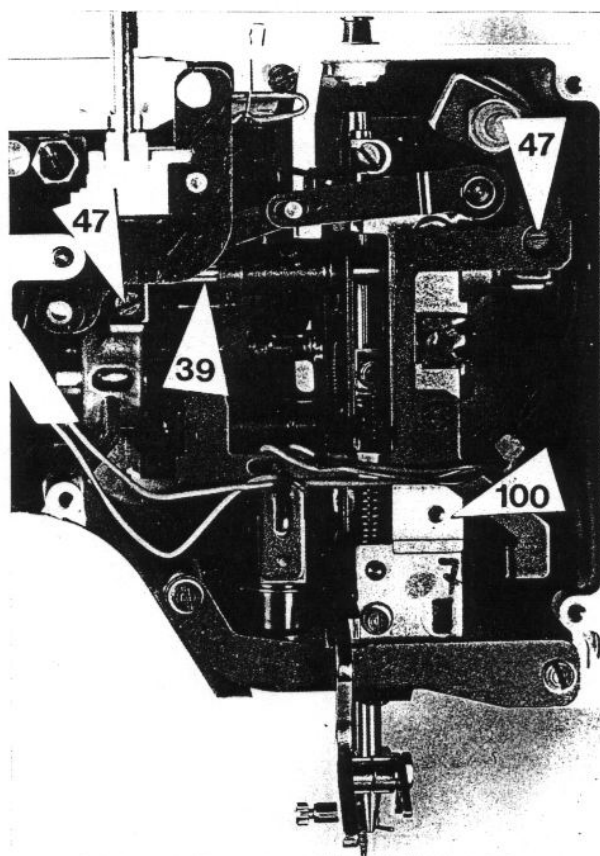

## 29 Checking the thread guide plate position

- Position the needle to the right.
- The edge of the needle should be about 0,3 mm to 0,5 mm from the thread guide plate opening (see illustration).

### Correction

- Loosen both fixing screws (102).
- Move the thread guide plate (103) in the material feed direction so that the leading edge of the needle (No. 80) is 0,7 to 1,0 mm from the thread guide plate (103) to the right and left.
- The lateral position of the thread guide plate (103) should be noted as described above.
- Tighten both screws (102).

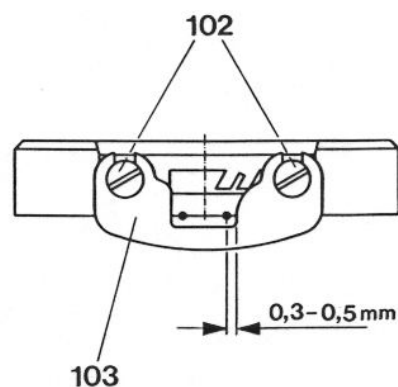

## 30 Needle plate adjustment

### Checking the needle plate position

- Insert needle Nm (90).
- The needle must penetrate at the center of the stitch hole as seen in the direction of the material feed.

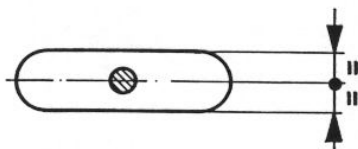

### Correction

- Loosen the nut of lock-bolt (106) (underneath the needle plate).
- Place the needle plate in the prescribed position.
- Tighten nut (106).

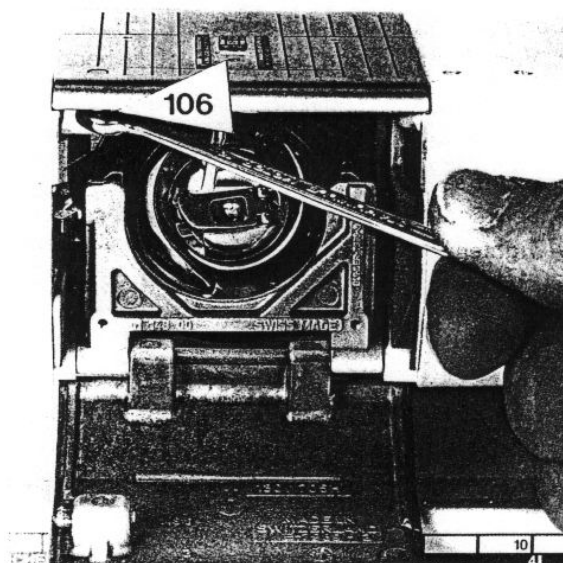

## 31 Checking the feed synchronisation

- Set the needle position knob L.M.R. to the center.
- Set the feed dog to the sewing position.
- Put the feed switch knob in the green position.
- Set the maximum stitch length 5 mm.
- Turn the handwheel in the direction of rotation until the lower edge of the needle eye is flush with the upper edge of the throat plate.
- The back of the feed dog should now be 0,2 to 0,3 mm below the upper edge of the throat plate.

### Correction

- Remove the stepped pulley (95).
- Tighten 4 mm screw (107) into tapped blind hole in the base shaft (108).
- Loosen the 2 screws (109) on the bevel gear (110).
- Turn the base shaft (108) only slightly to the left or right with a screwdriver.
- Pull out the base shaft with screw (107).
- Set the bevel gear (110) without play in the teeth.
- Tighten screw (109).
- Check the axial clearance of the base shaft.
- Remove screw (107).

**Note:** By turning the base shaft to the left the feed dog will go down earlier.

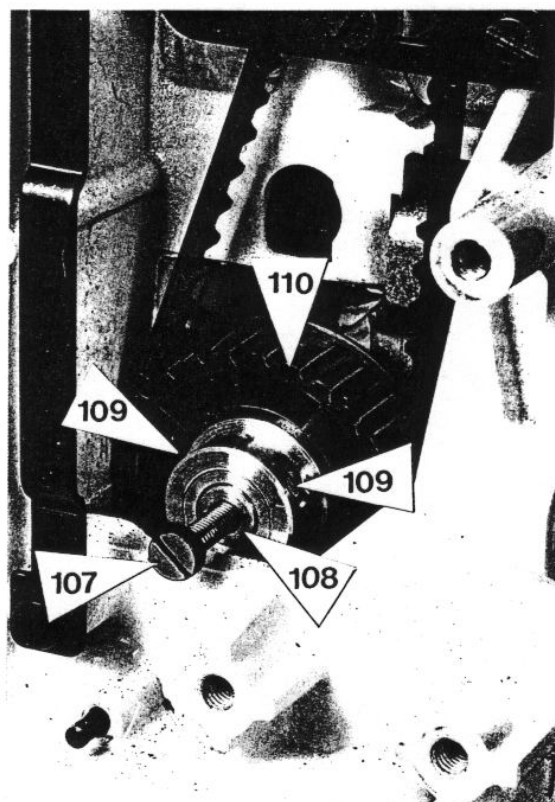

## 32 Checking the reverse feed synchronisation (red zone)

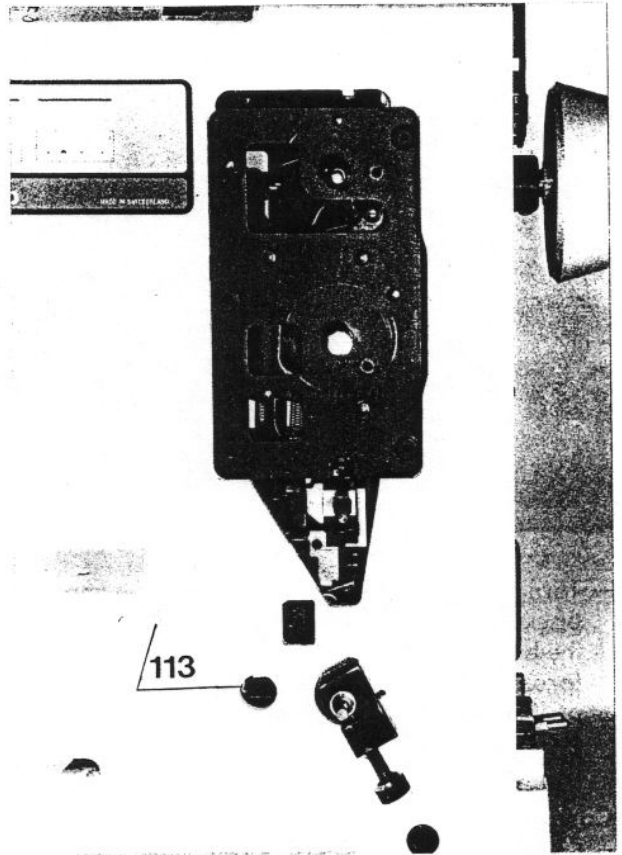
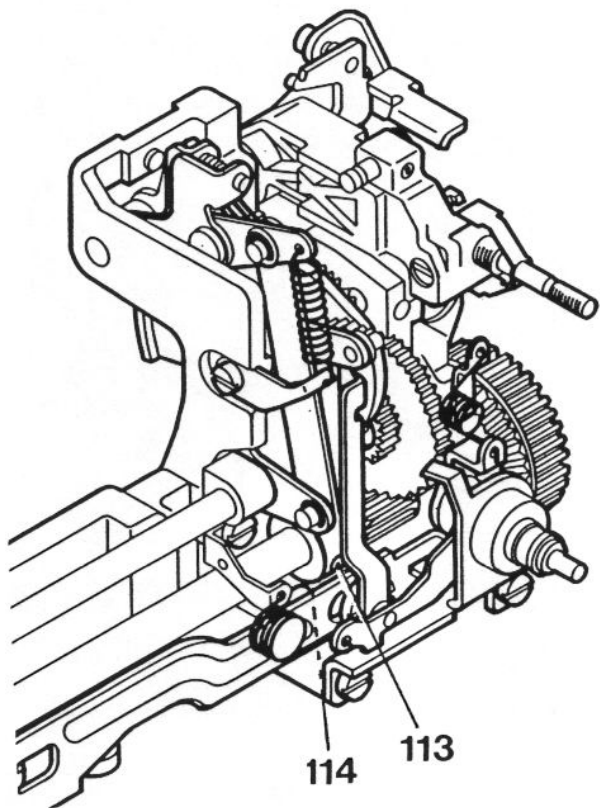

- Set the stitch length to maximum (5mm).
- Set the feed dog to the sewing position.
- Set the feed switch knob to the red zone.
- Turn the handwheel and note the front and rear reversing points of the feed dog. The reversing motion of the feed dog should be completed when the feed teeth are 0,2 to 0,3mm below the upper edge of the throat plate (during upwards motion).

### Correction

- Remove the L.M.R. knob, zig-zag knob, button-hole knob, stitch length knob, drop feed and reverse feed knob.
- Remove the scale plate, 3 securing screws.
- Set the feed control to green (clamping piece 112).
- Loosen screw (113) on the gearwheel.
- Loosen screw (114) and hold in position.
- Turn the handwheel forwards and backwards a little.
- Tighten screw (114) (gearwheel serves as setting collar).



## 33 Checking the synchronisation of the cam packet, to the reverse feed cam and main shaft

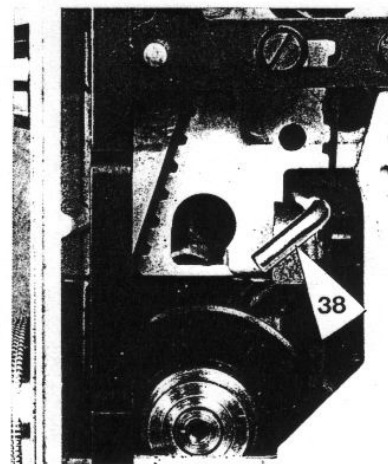
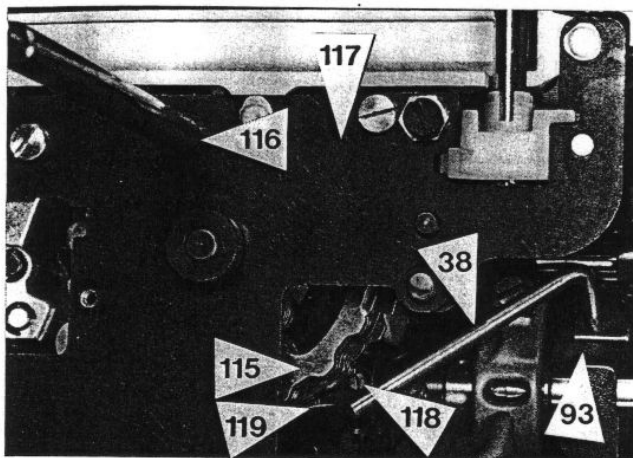

- Turn the handwheel until the bore in the cam packet (115) corresponds with the bore (116) in the bearing plate (117). Pin with 8 mm dowel (presser foot bar).
- Pin the feed control cam (96) with 4 mm pin (38).
- Pin the balance piece (93) with 4 mm pin (38).

### Correction

- Loosen the 4 screws (118) on the worm gear (119).

- Pin the feed control cam (96) into the first bore in the direction of rotation with a 4 mm pin (38).
- Pin the balance piece (93) with a 4 mm pin (38).
- Turn the worm gear (119) until the cam packet (115) can be pinned.
- Tighten one of the screws on the worm gear (119).
- Remove the 3 pins.
- Install the stepped pulley (see section 19).

## 34 Checking the worm gear clearance

- There should be no play between the worm gear and the wormwheel. This should be checked at various points by turning the handwheel. The machine should always run smoothly without jamming.

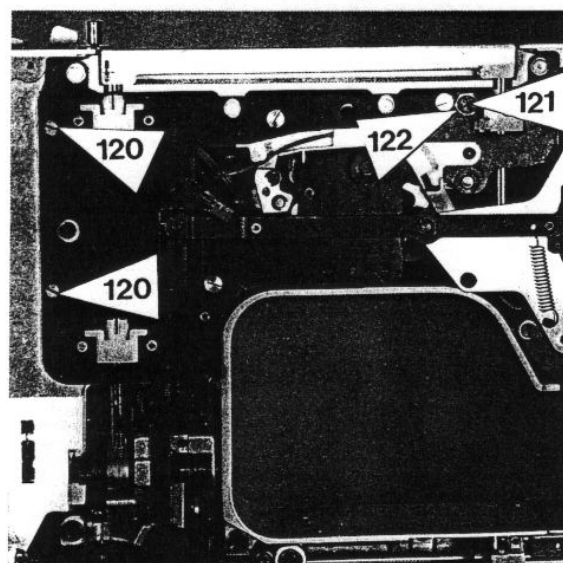

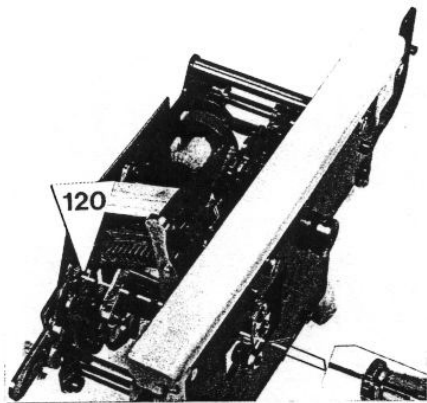

### Correction

- Loosen screws (120) slightly.
- Loosen screw (121).
- Turn the eccentric (122) as required.
- Tighten screw (121).
- Tighten screw (120).

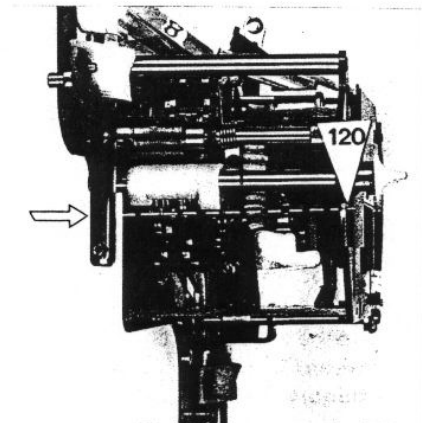

Note: Turning the eccentric to the right reduces the clearance.

## 35 Checking the zig-zag stitch distribution

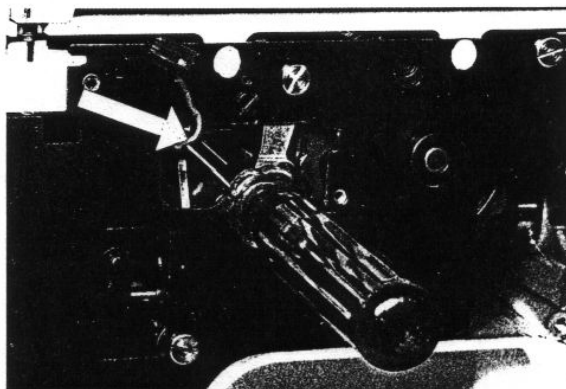

- Set the zig-zag knob to maximum (5,5mm).
- Turn the handwheel and note whether the left-hand and right-hand needle penetration points are equidistant from the edges of the stitch hole.

### Correction

- Slightly loosen screw (123).
- Insert the eccentric key (28) into the cam control lever (67).
- Bring the needle to the correct position by turning the eccentric key (28).
- Tighten screw (123).

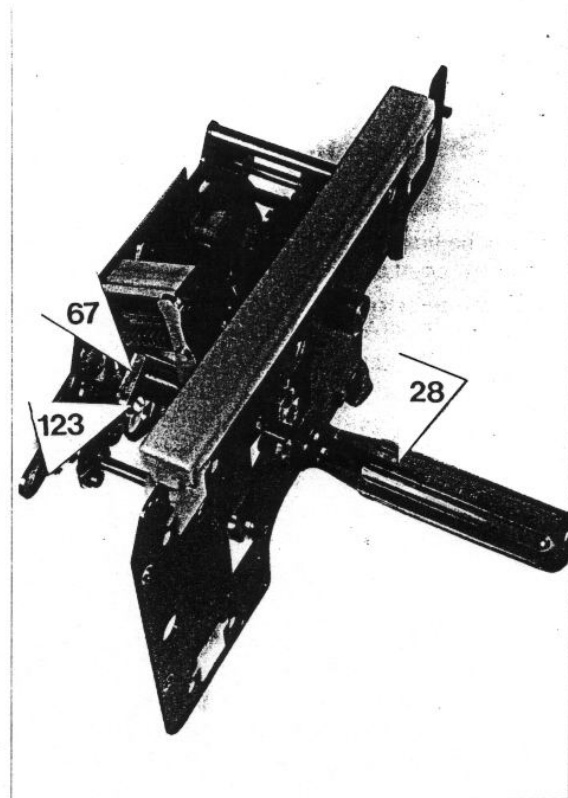



## 36 Lateral motion of the needle (parabola)

### Checking the needle motion above the stitch plate

- Remove the scale plate (125), which has 2 screws.
- Set the L.M.R. knob in the middle.
- Set the needle in the upper position with the handwheel (note the upwards motion of the tracer).
- Move the zig-zag stitch width knob to and fro between "0" and "5". **The needle must remain stationary.**

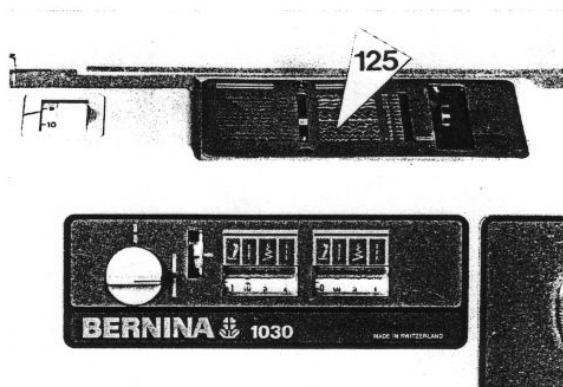

### Correction

- Loosen the 4 screws (118) on the worm gear (119) and secure them.
- Turn the handwheel slightly forwards or backwards until the correct position is found.
- Tighten the screws (118).

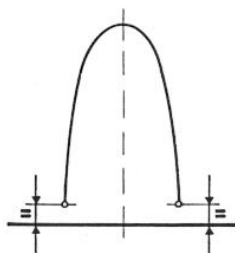
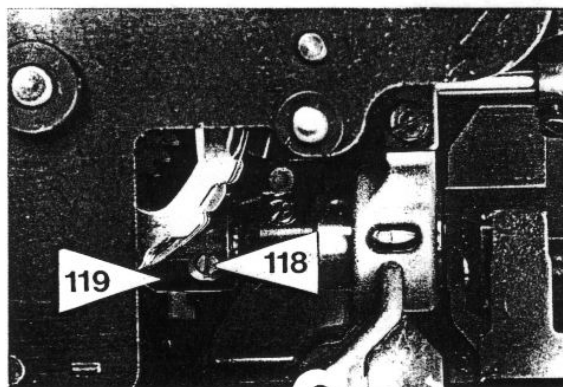

## 37 Checking the tracer lift

- Remove the scale plate (125).
- Turn the handwheel until the tracer comes to the highest point of the zig-zag cam.
- Pull the selector lever (126) to the right as far as the stop. Then move the tracer from front to rear, checking that it does not touch a cam. On the other hand the needle must remain in the stitch hole, under no circumstances must the needle come onto the stitch plate.

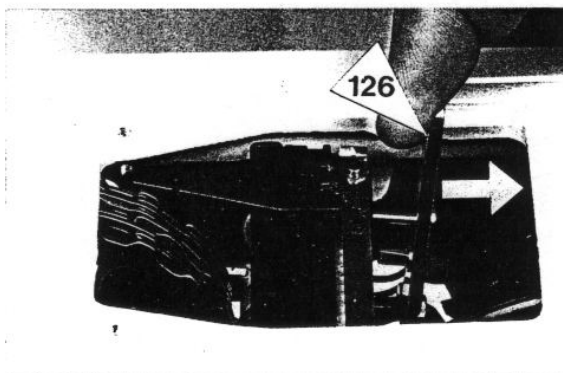

### Correction

- Loosen the locknut (127).
- Move the selector lever (126) to the right as far as the stop.
- Set the needle point flush with the throat plate by turning the handwheel.

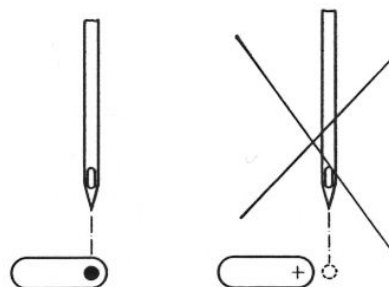

- Turn the eccentric (128) with a screwdriver so that the needle penetrates the stitch hole (on the extreme right).
- Tighten the locknut (127).

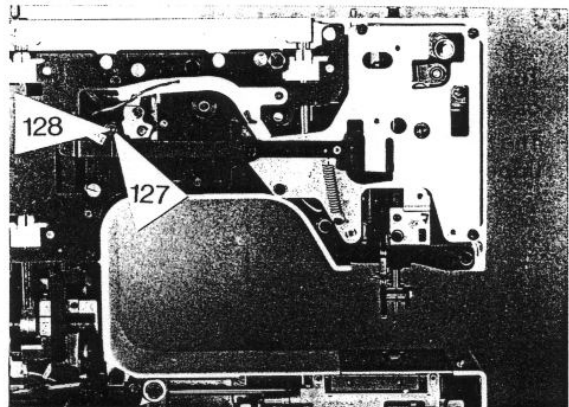

**Check:**

- Move the tracer from front to rear and check that it does not touch any of the cams.

## 38 Checking the scale for needle position, stitch width, stitch length and presser foot

- Set the selector lever (126) to position 8. The scale (153) should be equally distributed to the top and bottom.

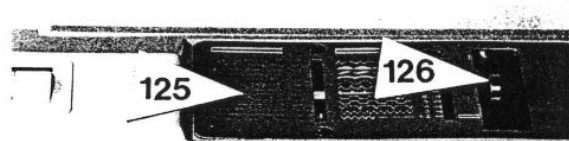

Check on pos. 1/2 and 13.

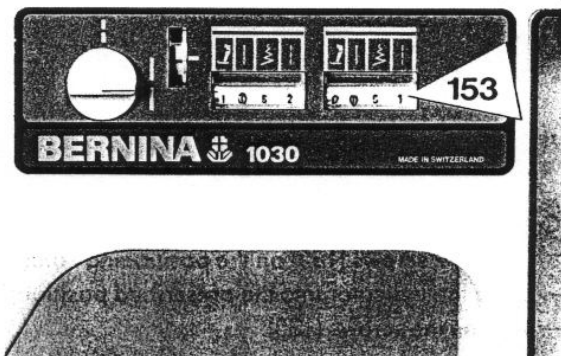

**Correction**

- Set the selector lever (126) to position 8.
- Remove the scale plate (125).
- Loosen screw (131).
- Move the spiral spring upwards or downwards until the scale (153) is equally distributed.
- Tighten screw (131).

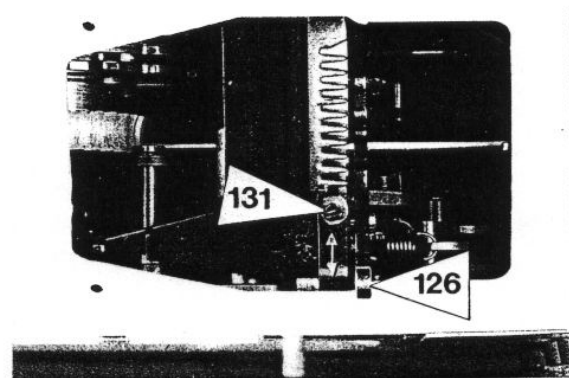

## 39 Checking the stitch length adjustment knob

- Turn the stitch length adjusting knob to the right as far as the stop.
- The mark on the front of the knob must be in the uppermost position.

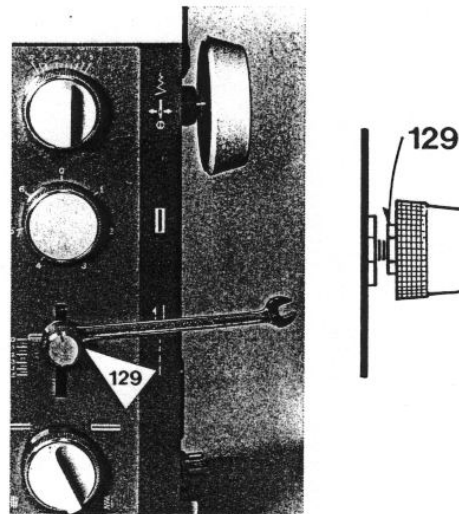

### Correction

- Hold the stitch length knob and loosen the 7 mm hex. nut (129).
- Bring the stitch length knob into the prescribed position.
- Tighten the hex. nut (129).

## 40 Checking the stitch length stop positioning cam

- Turn the stitch length adjusting knob to the right as far as the stop.
- The indicator must indicate "0".

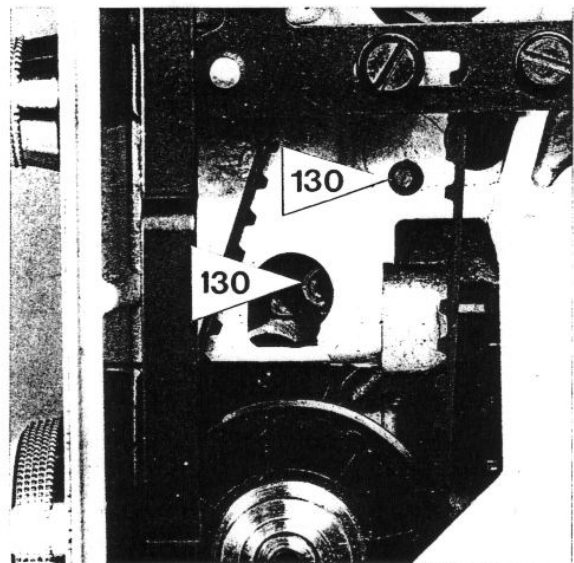

### Correction

- Loosen 2 screws (130) on the positioning cam.
- Bring the indicator into the prescribed position.
- Tighten the screws (130).

## 41 Checking the zero position of the feed control crank

- Set the stitch length knob to "0".
- Set the feed switch knob to "red".
- Set the feed crank tracer (133) to the lowest point of the feed cam (reverse feed).
- Move the feed crank (133) radially by hand. The stitch positioning crank should remain stationary.

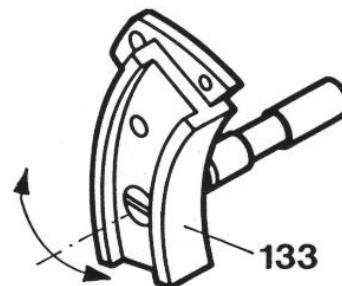

Check with 2,5 mm spez. allen key (15).

**Correction**

- Turn the screw (134) on the intermediate lever to the left or right as necessary, until the stitch positioning crank (135) remains stationary.

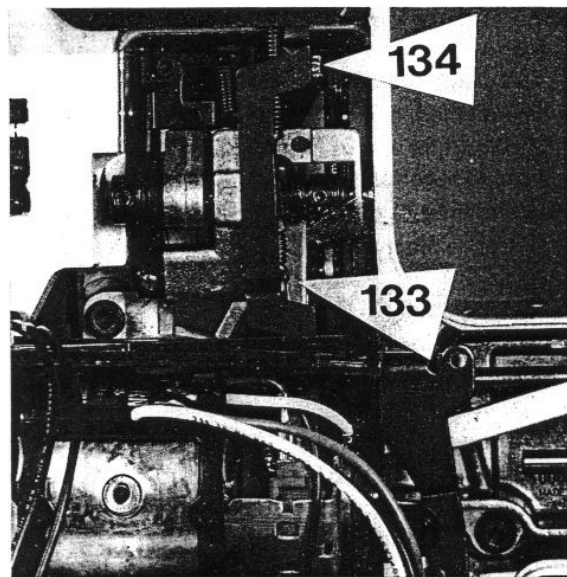
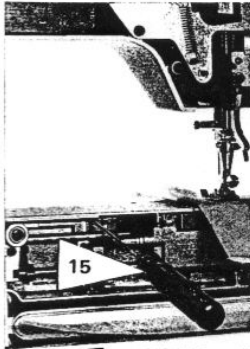

## 42 Checking the zero position of the stitch length crank

- Install the motor (2 screws)
- Install the L-print 1030-1020 (without screws).
- Connect the mains plug P 150, motor plug P 151 and foot control plug P 156.
- Install the service cover.
- Set the stitch length adjustment lever to "0".
- Set the feed switch knob to "green".
- Place cotton crettonne material under the presser foot.
- Allow the machine to run.

**Correction**

- Insert 2,5 mm spez. allen key in the screw (136) on the stitch position crank (135).
- Allow the machine to run.
- Loosen screw (136) and turn the key radially until no feed occurs.
- Tighten screw (136).

*Attention:* The material should not be move.

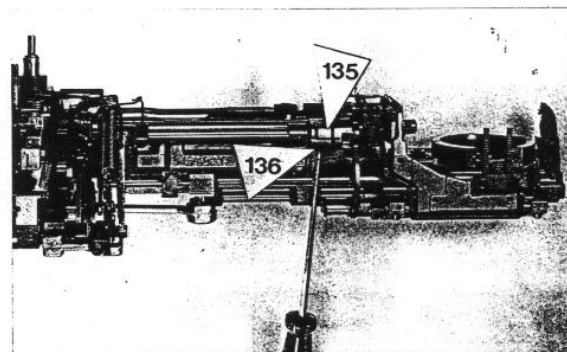
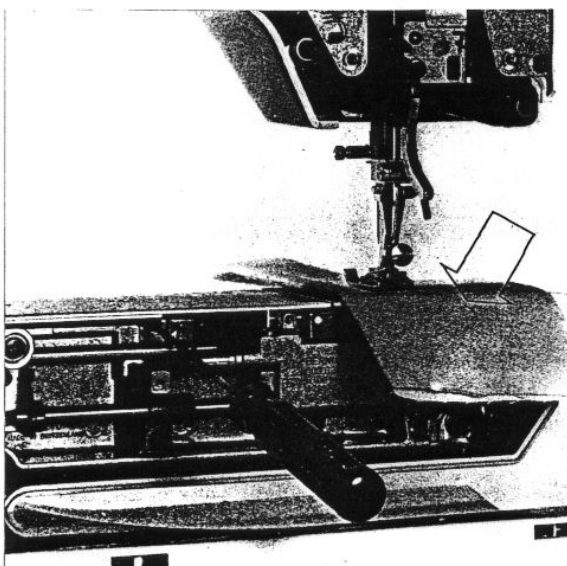

## 43 Checking the forward-reverse feed equalization (honeycomb stitch)

- Install the motor (2 screws).
- Install the L-print 1030–1020 (without screws).
- Connect the mains plug P 150, motor plug P 151 and foot control plug P 156.
- Install the service cover.
- Prepare the machine for sewing (presser foot No. 1).
- Set the stitch length to 2,5 mm.
- Set the selector lever (126) to stitch 16 (honeycomb stitch).
- Set the feed switch knob to "red".
- Set the zig-zag knob to max. stitch width "5".
- Allow the machine to run.
- The honeycomb stitch should be of the correct pattern (1).

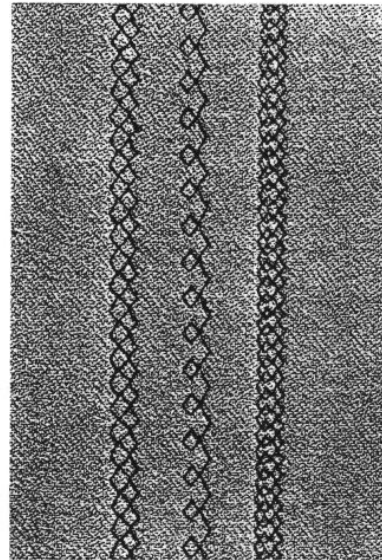

I II III

- I = Correct
- II = Forward stitches too long
- III = Forward stitches too short

### Correction

- Unplug the power supply cable.
  - Remove the service cover.
  - Swing the L-print to the rear.
  - Insert 2,5 mm spez. allen key into the eccentric (137) on the feed control crank.
  - Loosen the 1,5 mm. Allen screw (138).
  - Turn the eccentric to the left or right as necessary.
  - Tighten the 1,5 mm screw (138).
- Turning the eccentric to the left makes the forward stitches longer.

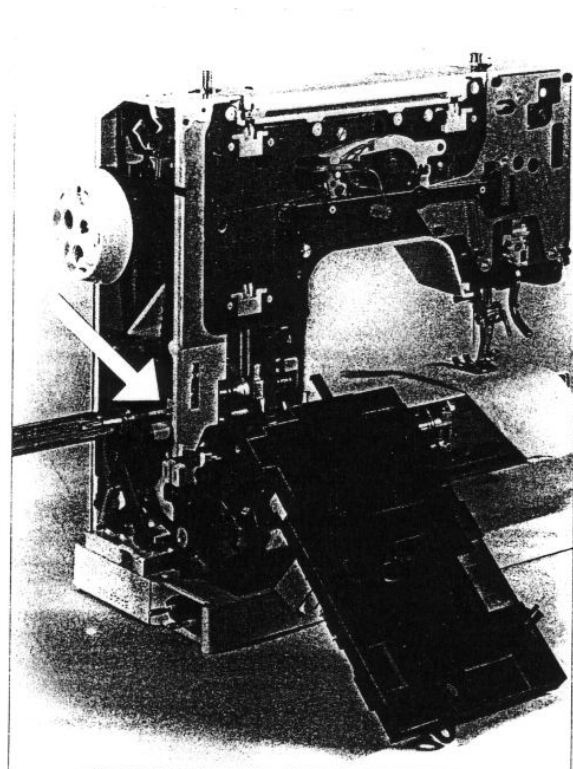
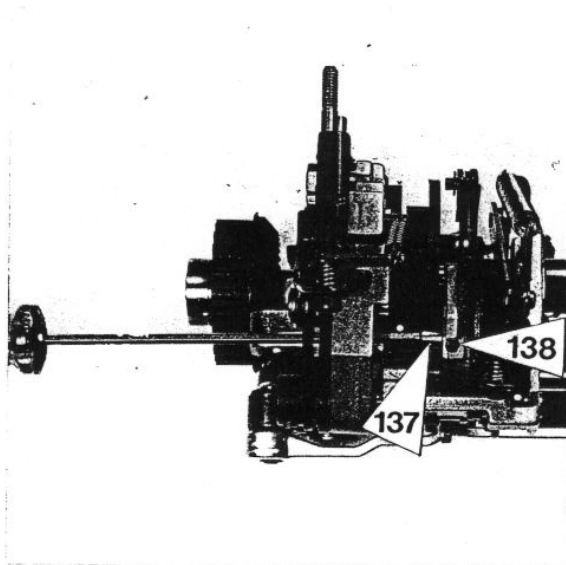

## 44 Checking the tracer position with the reverse feed switched off

- Remove the service cover.
- Remove the plugs P150, P151 and P156.
- Remove the L-print 1030–1020.
- Connect plug 151 to the special mains adaptor.
- Set the feed switch knob to "green".
- Switch on the main switch of the special mains adaptor.
- Allow the motor to run.
- By placing a finger on the crank (133), check, that the tracer (137) of the feed-dog crank (133) contacts the feed-dog cam.

The clearance between the tracer and the cam must be 0 to 0,05 mm.

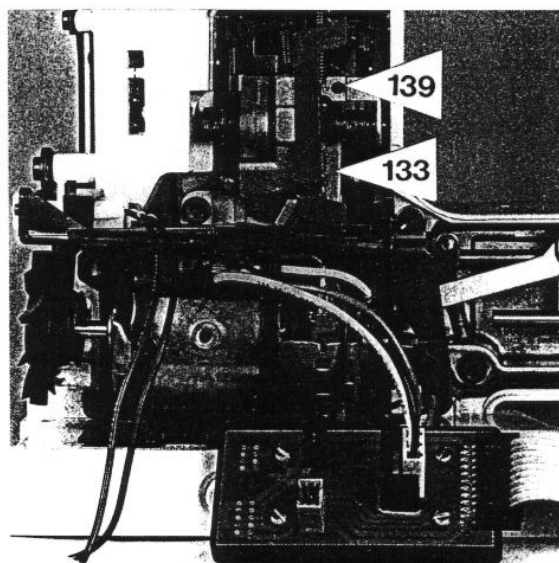
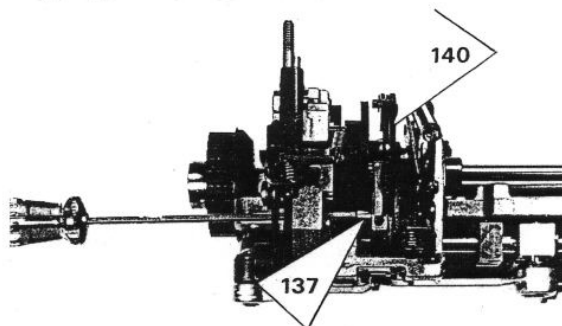

### Correction

- Adjust the change-over (140) with the adjusting screw (139) until the correct tracer clearance is achieved.

## 45 Buttonholing 45 Checking the density of the bar tack:

- Remove the service cover.
- Unplug P150, P151 and P156.
- Remove L-print 1030–1020.
- Connect plug P151 to the special mains adaptor.
- Set the feed switch knob to "green".
- Switch on the special mains adaptor.
- Attach buttonhole foot No. 3.
- Place the material under the buttonhole foot.
- Set the stitch length to 0,5 mm.
- Set the buttonhole knob to position 3.
- Allow the sewing machine to run. The material should not feed.
- Check at position 5.



### Correction

- turn the 2,5 mm screw (141) on the adjusting lever to the left or right as necessary, until the material no longer feeds.

Note: Turning the adjusting screw (141) to the left results in forward feed.



## 46 Checking the cutting space and bead width

- Install the L-print 1030–1020 (without screws)
- Connect the mains plug P150, motor plug P151 and foot control plug P156.
- Install the service cover.
- Insert the needle.
- Attach the buttonhole foot (carrage foot).
- Thread the machine.
- Set the stitch length to 0,5 mm.
- Set the feed switch knob to "green".
- Place two layers of cotton cretonne under the foot.
- Sew in buttonhole position: 1 first bead  
2 reverse straight stitch  
4 second bead

### Check

1. Visual check
2. Needle penetration points on paper
  - Lower the feed dog.
  - Place a piece of paper under the buttonhole foot.
  - Select buttonholing position 1.
  - Turn the handwheel forwards and backwards until two small needleholes are visible (leave the paper under the foot).
  - Turn the buttonholing knob to position 4.
  - Turn the handwheel forwards and backwards again until two small needle-holes are visible.
  - Compare needle penetration positions 1 and 4 by measuring.

### Theoretical measurements:

- Back tack width 4,35 mm
- Bead width 2,03 mm
- Cutting space 0,40 mm

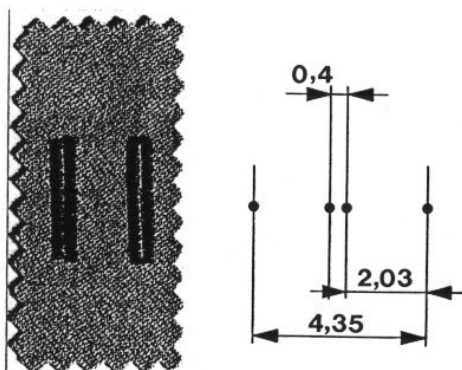

### Correction

- Remove the L.M.R., zig-zag, buttonholing, stitch length, drop feed and feed switching knobs.
- Remove the scale plate (111), which has 3 screws.
- Loosen the 5,5 mm locknut (142).
- Turn the eccentric pin (143) to the left or right as necessary.
- Tighten the locknut (142).

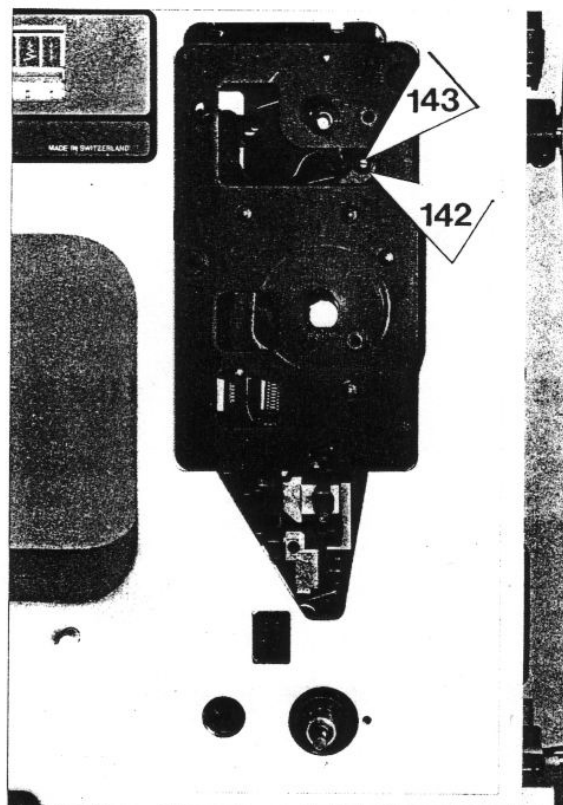
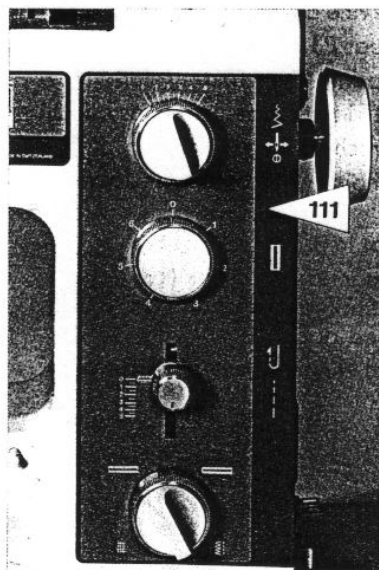

Carry out check 2 first and then check 1.  
Assemble in the reverse order.

## 47 Needle stop

### Checking the needle stop setting

- Allow the machine to run and then stop.
- The leading edge of the thread take-up lever should be flush with the inner edge of the housing.

### Correction

- Loosen the screws (144) on the light barrier eccentric.
- Turn the eccentric as required.
- Tighten the eccentric (144).

Turning the eccentric clockwise moves the thread take-up lever to the rear.

**Caution:** After setting the light barrier eccentric make sure that it rests on the belt pulley, which serves as a setting collar.

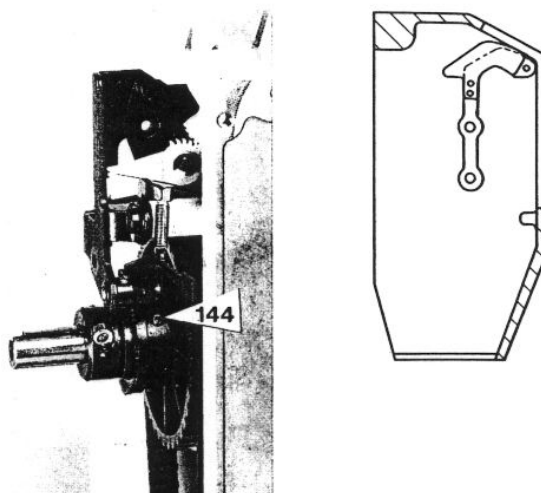

## 48 Automatic long stitch device

### Checking the needle bar guide

Uncouple the needle bar by hand. By turning the needle bar to the right and left establish the amount of guide play, and whether the coupling pin can latch in smoothly.

### Correction

- Remove rigidity plate (44).
- Place needle bar to its top dead center.
- There should be a play of 0,5 mm between the needle bar guide (145) and the carrier (148).
- Loosen needle bar guide (145).
- Engage needle bar (146) in coupling pin.
- Middle out any play from the needle bar (146) inside the coupling pin.
- Place distance gauge 0,5 mm (147) between needle bar carrier (148) and needle bar guide (145).
- Using a screwdriver press the needle bar guide (145) against the gauge.
- Tighten screw of the needle bar guide (145) (observe the distance 0,5 mm).
- Check that it functions. (The latch for uncoupling is visible through the slit for the thread take-up lever.)

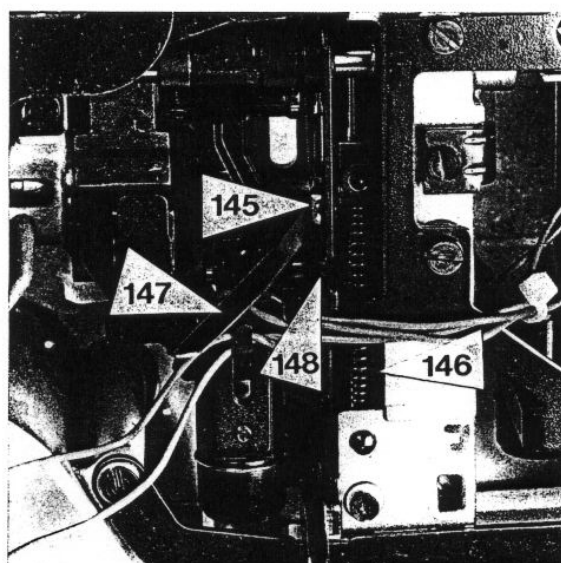
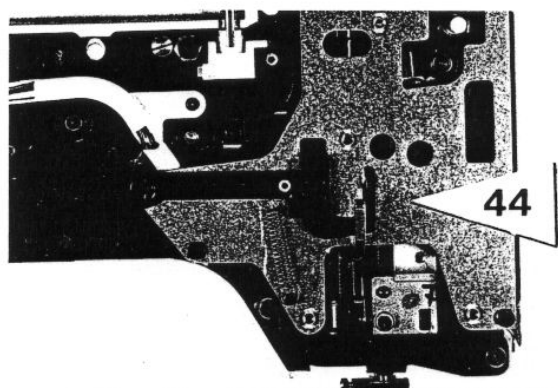



## 49 Checking the basic setting of the latch release pin

- Set the L.M.R. needle position to the left.
- Switch on the automatic long stitch.

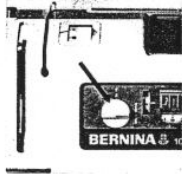

- Turn the handwheel until the release pin (149) is on the left.
- Bring the needle bar to the highest positions.
- There should now be a clearance of approx. 0,3 mm between the release bolt and the left-hand edge of the latch (150). This is visible through the thread take-up slit.

### Correction

- Remove the reinforcement plate (4 screws and knee lever circlip).
- Remove the screw (151) from the transmission lever.
- Insert a 0,3mm feeler gauge between the release pin (149) and the spring lever (152). Slightly push to keep in position.
- Tighten the screw (151).

Check: Funktion of needle-position LCR right.

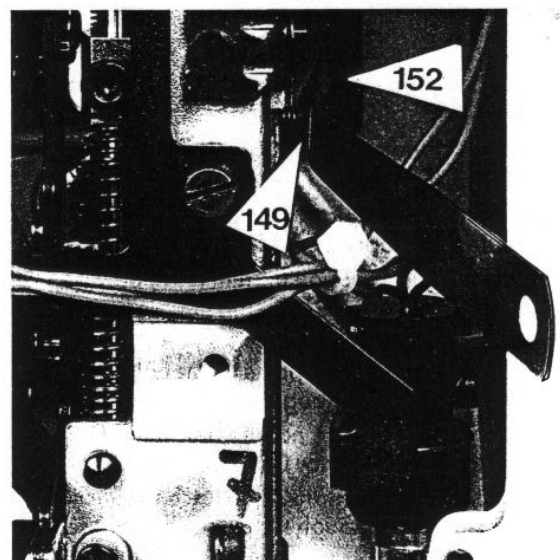
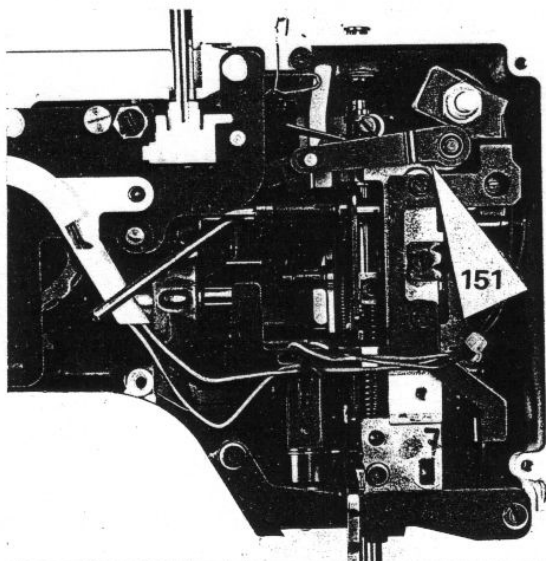
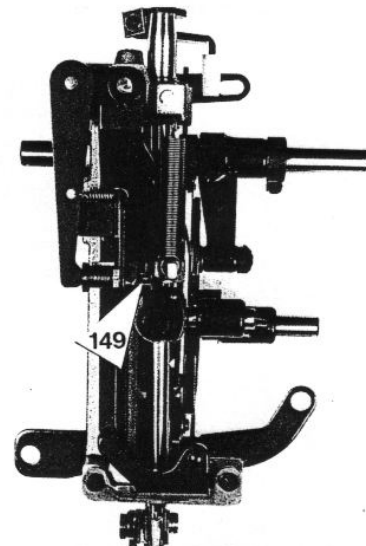
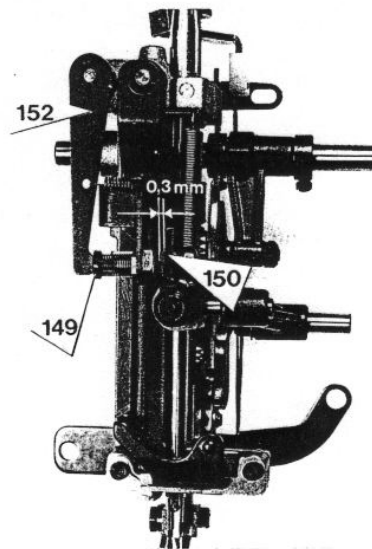

## 50 Checking the instant of decoupling

- Position needle to the left.
- Press the button for automatic long stitch.
- Now the needle bar should only decouple approx. 12 degrees before reaching top dead center.

After every change or adjustment of the automatic long stitch, the cushioner sleeve should be checked and set.

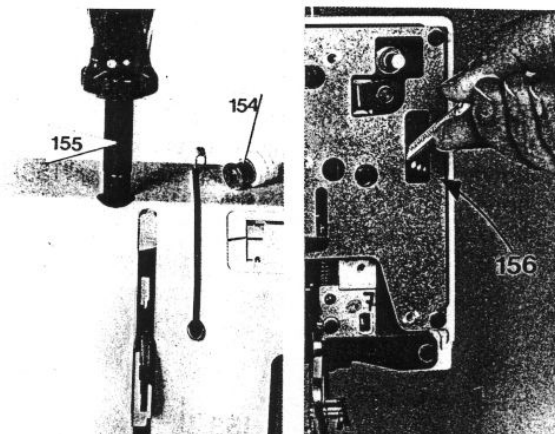

### Correction

- Screw out the bobbin winding pre-tensioner (154).
- Using socket wrench (155) screw out the puffer by three revolutions.
- Loosen hexagon head screw (156) in the head frame.
- Turn adjusting screw (157) accordingly. (The release pin is hereby adjusted.)
- Tighten screw (156).

Note: Turning anti-clockwise the coupling point will be earlier.

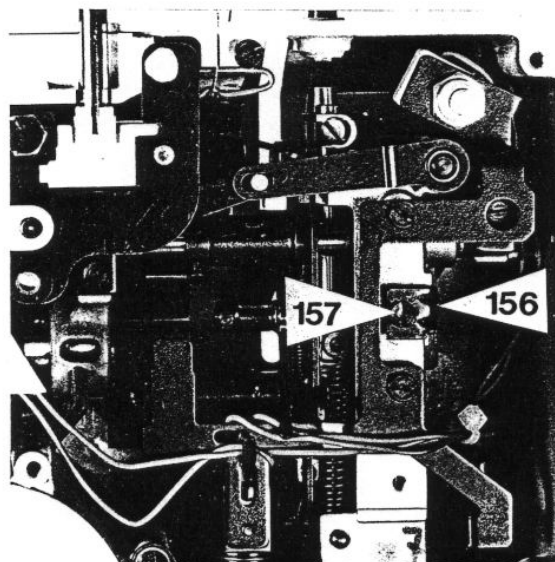

## 51 Checking the cushioner position

- Position the needle to the right.
- Press the button for automatic long stitch.
- Uncouple needle bar and push it twice by hand into the puffer.
- Run the machine with a max. speed of 1050 Rev./min. After a few turns the needle bar should become engaged.

### Correction

- Screw out the bobbin pre-tensioner (154).
- Using socket wrench (155) screw out the puffer (158) by three revolutions (anti-clockwise).
- Position the needle to the left (straight stitch).
- Press button for automatic long stitch and run the machine slowly. Using socket wrench (155) slowly screw down (clockwise) cushioner (158) slowly, until the needle bar is able once again to couple.

- Tighten plastic screw (159).
- Fit bobbin pre-tensioner (154).

### Checking

See checking!

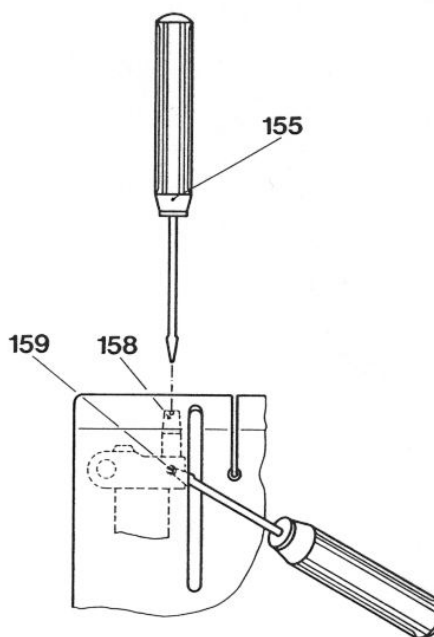
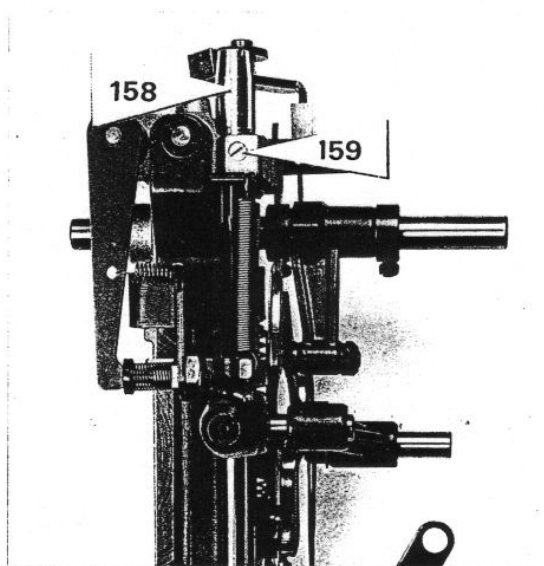

## 52 Basic adjustment to the knee lifter lever

The end of the knee lever should be vertical under the edge of the free arm end.

### Knee lifter lever adjustment

The knee lifter lever can be adapted to suit each individual customer.

### Correction of knee lifter position

- Loosen screw (161) to the feed-dog drop unit.
- Insert knee lifter lever (160).
- Loosen hexagon head screw (162) of the clamp.
- Bring the knee lifter lever to the convenient position.
- Tighten hexagon head screw (162).

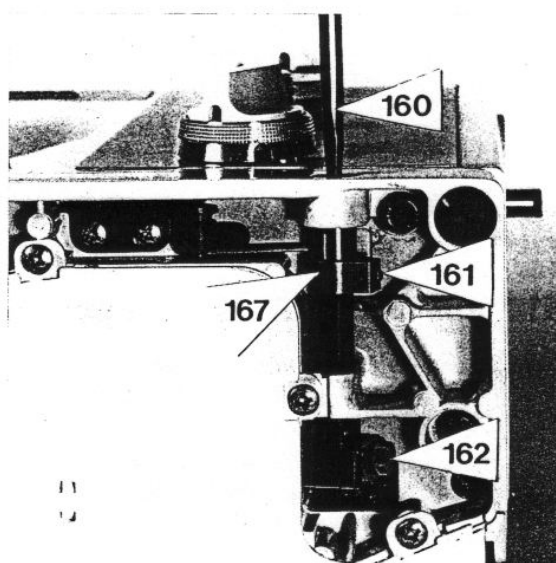

## Adjustment of the lifter lever release mechanism (without chassis cover)

- Lower presser foot.
- Loosen screw (163).
- Move stop (164) until it is about 1 mm off the thread tension release catch (165).
- Tighten screw (163).

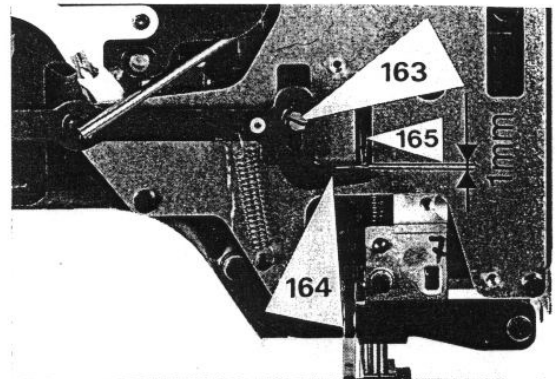

## 53 Checking the lowering of the feed-dog

- Turn the handwheel until the feed-dog is in its highest position.
- Operate the knee lifter lever.
- After raising the presser foot (approx. 4 mm above the needle plate) the feed-dog should lower.

### Correction

- Turn the handwheel until the feed-dog is in its highest position.
- Loosen screw (161).
- Tighten securing piece (167) of the disengaging lever in the direction of the arrow.
- Tighten screw (161).

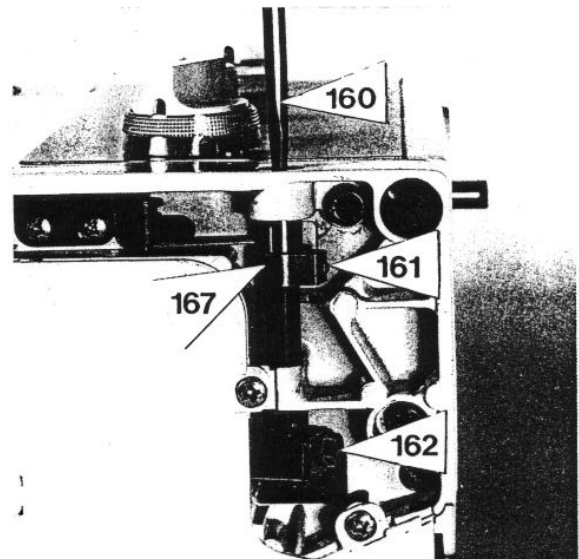

## 54 Lower thread tension

For testing use synthetic thread No. 100/3 ply, white, left twist. This thread is contained in the bobbin case of every new machine. The lower thread tension is checked with the movable setting weight No. 398 118 040. The bobbin case is placed in the weight gauge just as in the hook.

## Checking

Hold the free end of the thread and suspend the bobbin case with the movable setting weight (without any additional weight). The bobbin case must not move downwards. After attaching an additional weight (5 grammes) the thread should move downwards (speed 1 m/2–4 sec.). If you test with darning thread the speed should be 1 m/25 sec. Regulation of the lower thread tension is made with the bobbin case adjusting screw and a small screwdriver.

Turning left = weaker

Turning right = stronger

In order to check the spring condition completely, the tension set should be checked with the weight on the left and the right side. (Adjust the tension spring when necessary).

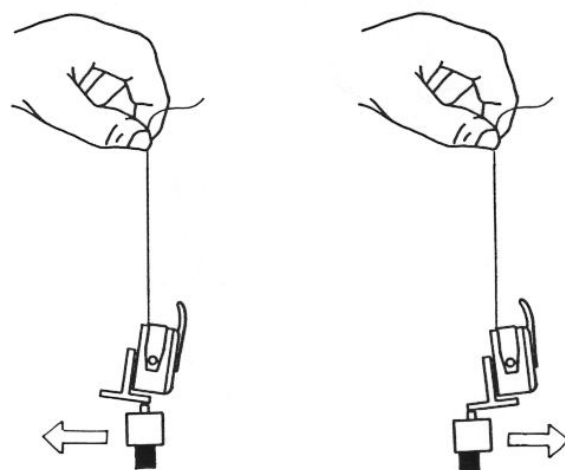
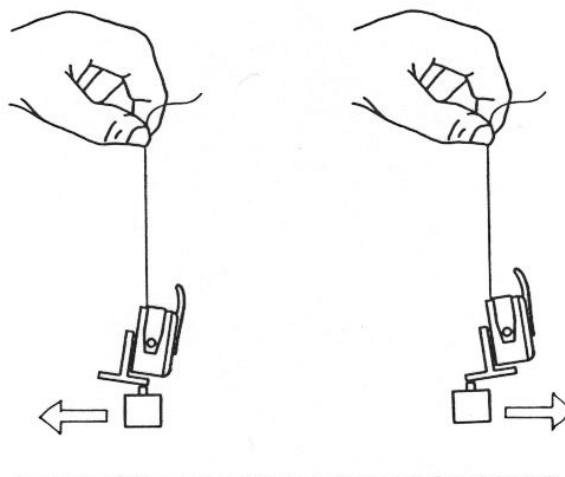

## 55 Basic adjustment of the upper thread tension

### Checking

- Use synthetic thread No. 100/3 ply above and below.
- Test bobbin case with prescribed weight.
- Line up the red mark on the adjusting dial with the mark on the housing.
- Trial run with the running stitch.

### Correction

- By turning the thread tensioning spindle (168) the basic adjustment can be made.
- Using 2,5 mm allen key (shortened) through the thread take-up lever slit, turn thread tensioning spindle (168) accordingly.
- (Turn anti-clockwise for less, turn clockwise for more tension.)

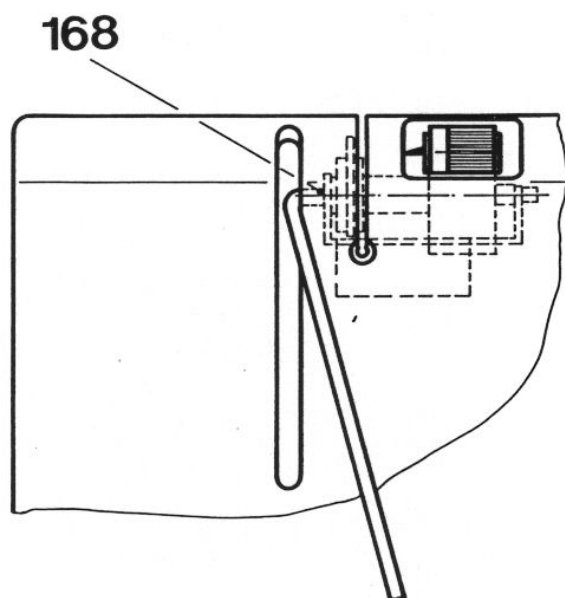

## Adjustment of the upper thread tension with a weight

- Test thread 120/2 ply.
- Thread machine up including thread take-up lever.
- Position the thread take-up lever with needle bar at its highest point.
- Lower presser foot.
- Line up the red mark on the adjusting dial with the mark on the housing.
- Attach the upper thread tension weight of 85 grammes.
- Draw approx. 30 cm of thread off the bobbin.
- The thread tension weight should hang and not move.
- Only when an additional weight of 8 grammes is attached should the thread be drawn very slowly.

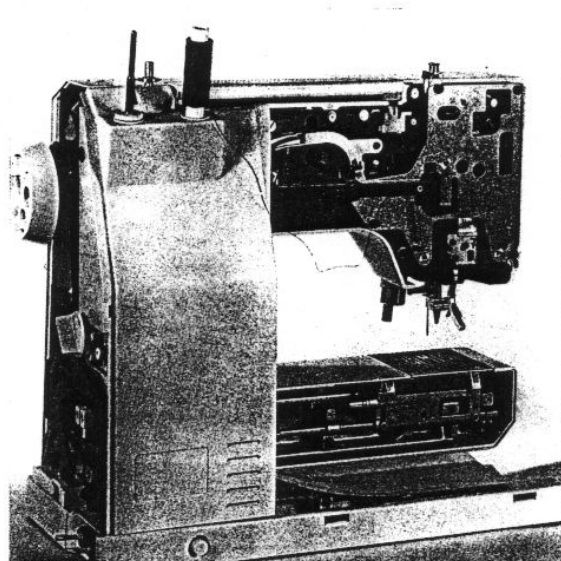
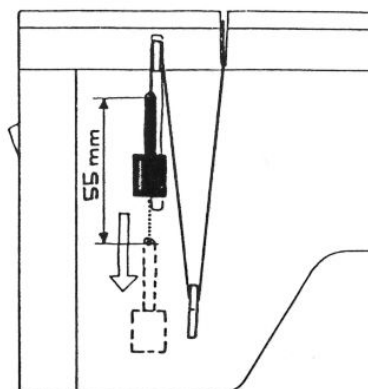

## Correction

- Adjustment is made by turning the thread tensioning spindle (168).
- Using 2,5 mm allen key (shortened) through the thread take-up lever slit, turn thread tensioning spindle (168) accordingly.
- Turn anti-clockwise for less, turn clockwise for more tension.

## 56 Removing the needle drive assembly

- Completely remove the belt and chassis covers and the chassis.
- Remove all control knobs and scale plates.
- Remove the automatic buttonholer (3 screws No. 25).
- Remove the bobbin winder retaining plate (27) (3 screws [26]).
- Dismantle the stepped pulley (remove the belt from the handwheel flange).
- Loosen the belt tensioner. (Tighten screw slightly after loosening.)
- Remove the lighting cable and also the cable ducts.

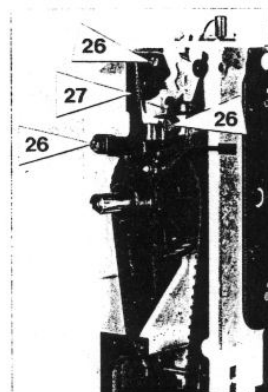
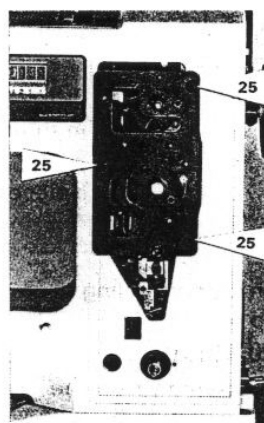



- Loosen the 4 screws on the worm gear (119) by at least one turn.
- Remove the presser foot and needle.
- Remove the knee lever lifter and circlip.
- Remove the reinforcement plate (44).
- Remove the two screws (168) and complete light mounting (170).

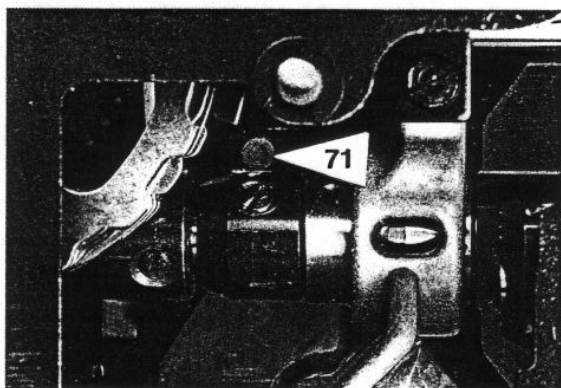
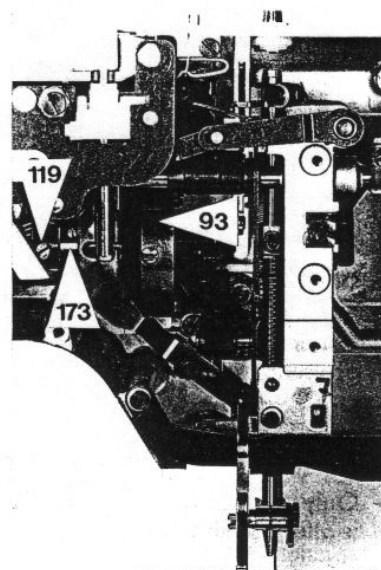
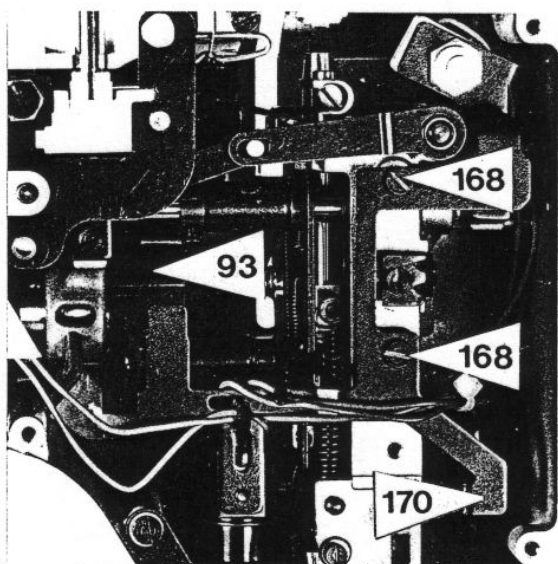

**Before going any further, the head frame must now be removed (see section 70)**

- Loosen the handwheel flange and remove it.
- Loosen the setting collar (173) on the main shaft bearing.
- Remove the conical screw on the balance piece (93).
- Remove the upper shaft to the left.
- Remove the screw (71) on the connecting strap (remove connecting strap part).
- Remove the 6 screws (120, 121, 124).
- Remove the needle drive assembly from the rear.

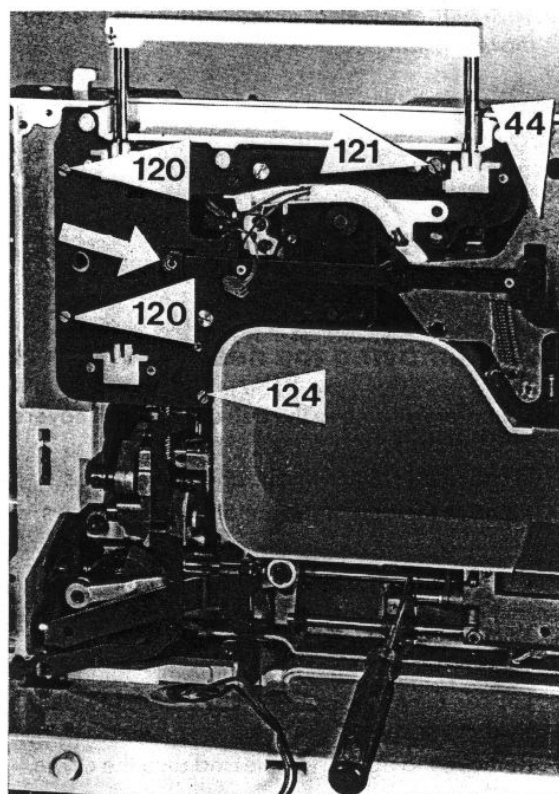

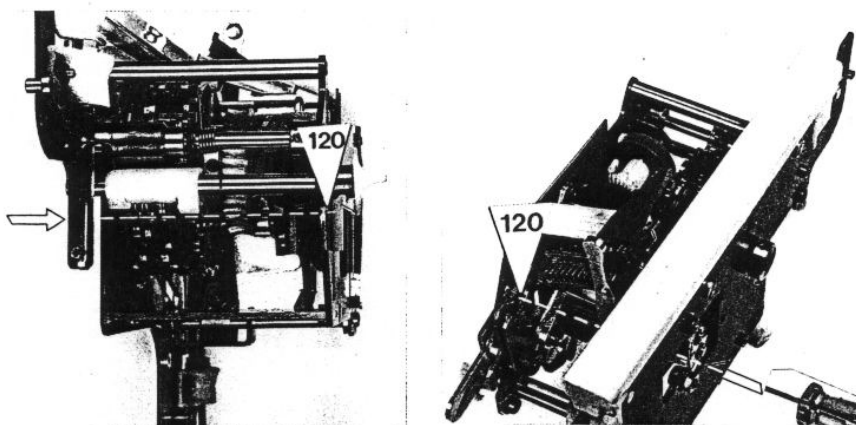

## 57 Installing the needle drive assembly

- Insert the complete needle drive assembly (pin the cam packet with 8 mm pin).
- Set the eccentric (122) with marking at 1 o'clock.
- Refit screws (120, 121, 124), then tighten screws (121, 124).
- Refit the connecting strap (72).
- Pin the carrier and feed control cam (first hole in direction of rotation) with 4 mm pin.
- Refit the upper shaft, worm gear, setting collar, steel disc and balance piece for the needle drive.
- Adjust the upper shaft clearance.
- Refit the head frame (see section 71).
- Refit the automatic buttonholer complete with the 3 screws (pin automatic buttonholer at position 0 with 4 mm pin).
- Remove 4 mm pin from the automatic buttonholer.
- Check for correct functioning at buttonholing position 2 (easymovement L.M.R. and zig-zag knob).
- Refit the scale plate (3 screws).
- Refit the control knobs.
- Adjust the belt tension of the hook drive (see section 18).
- Refit the belt pulley (note position of clamping screw) see section 26, hook drive shaft.
- Turn the worm gear (119) as far as the stop setting collar.
- Tighten one screw.
- Remove three pins.

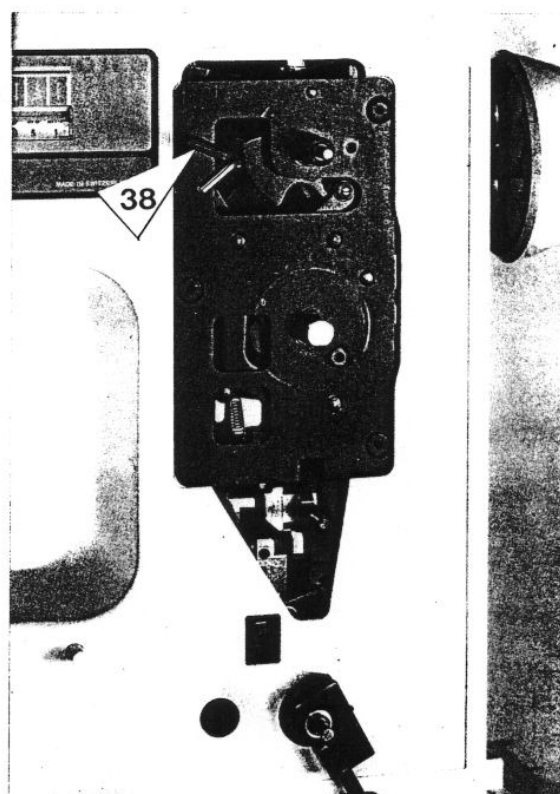

- Turn the needle drive eccentric (122) so that the cam packet is free of radial clearance (see section 34).
  - Tighten screws (121, 123, 124).
  - Install the bobbin winder retaining plate (see section 9).
- For further adjustments (see section 72).

## 58 Checking tracer position on the long stitch cam

- Fit the long stitch control knob.
- Set the control knob to long stitch (right-hand).
- The tracer (35) must be in the centre of the long stitch cam.

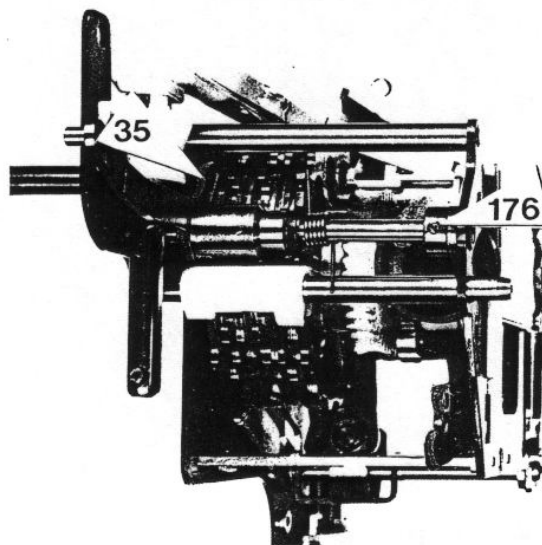

### Correction

- Loosen the screw (176) slightly.
- Turn the shaft to the left or right.
- Tighten screw (176).

## 59 Provisional checking of tracer lift (needle control)

- Pin the cam group with 8 mm pin.
- Set the tracer on the zig-zag cam.
- Pull the tracer adjustment lever (126) to the right. The clearance between the tracer (177) and the cam should be 0,05 mm (check with 0,05 mm feeler gauge).

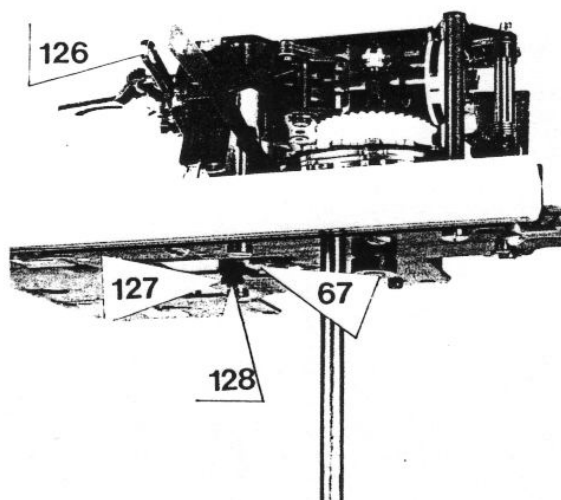
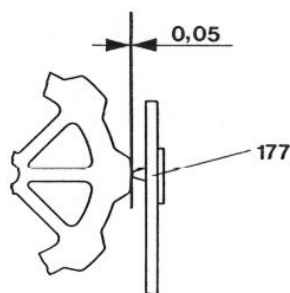

### Correction

- Loosen the locknut (127) of the eccentric (128).
- Insert 0,05 mm feeler gauge between the tracer and the cam.
- Set the eccentric (128) lightly against the cam operating lever stop (67) using a screwdriver.
- Tighten locknut (127).

### Check:

- turn the tracer adjusting lever (126) to the right and simultaneously move it backwards and forwards. The tracer must never catch on any of the cams.

## 60 Checking tracer distribution on the cams

- Set the tracer (177) on cams 1 and 12/10. It should be equally distributed on both sides of each cam.

### Correction

- Hold the eccentric pin (178) with 5,5 mm open end spanner.
- Loosen the locknut (179) with 5,5 mm open end spanner.
- Turn the eccentric pin (178) to the left or right as necessary.
- Tighten the locknut (179).

*Note:* The eccentric pin should always point downwards.

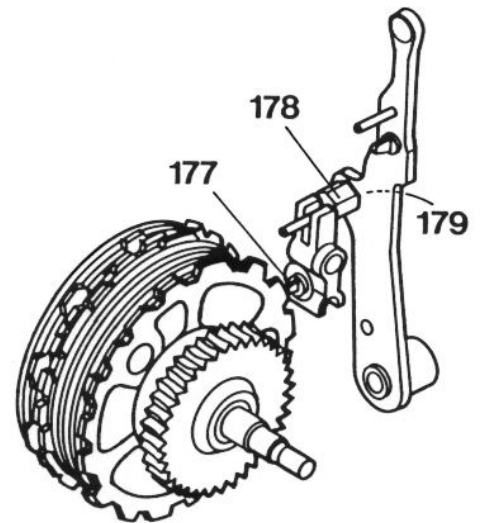

## 61 Checking the stitch pattern indicator

- Pin the cam group with 8 mm pin.
- The side marking (180) on the indicator should now be flush with the lower edge of the front bearing plate (see illustration).

### Correction

- Turn the indicator by hand into the correct position (only gentle effort is required).

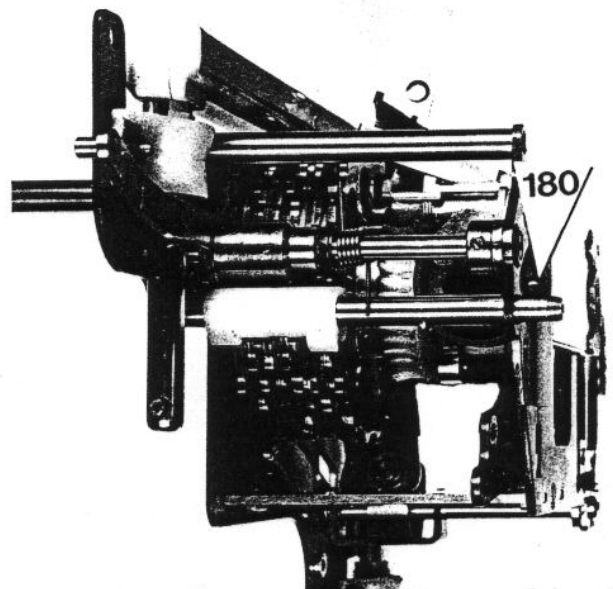

## 62 Removing the carrier for checking outside the machine

- Disconnect the belt and chassis cover, base cover, chassis complete, connecting straps and knee lifter lever (circlip). Remove the rigidity plate (183), and throat plate.
- Open the hook cover (remove the hook).
- Loosen the screw (161) of the feed-dog drop unit.
- Loosen the hex. screw (162) on the clamping piece (knee lifter shaft).
- Loosen the knee lifter shaft setting collar and remove the shaft.
- Loosen the feed-dog drop unit screws (184) and completely remove the lever.
- Remove the stepped pulley (three screws 65 and 66).
- Loosen the belt tensioner (64). Tighten the screw slightly after loosening.
- Remove the stitch length adjustment knob, feed-dog drop unit knob and feed switch knob.
- Remove the three allen screws (59).
- Remove the complete support.

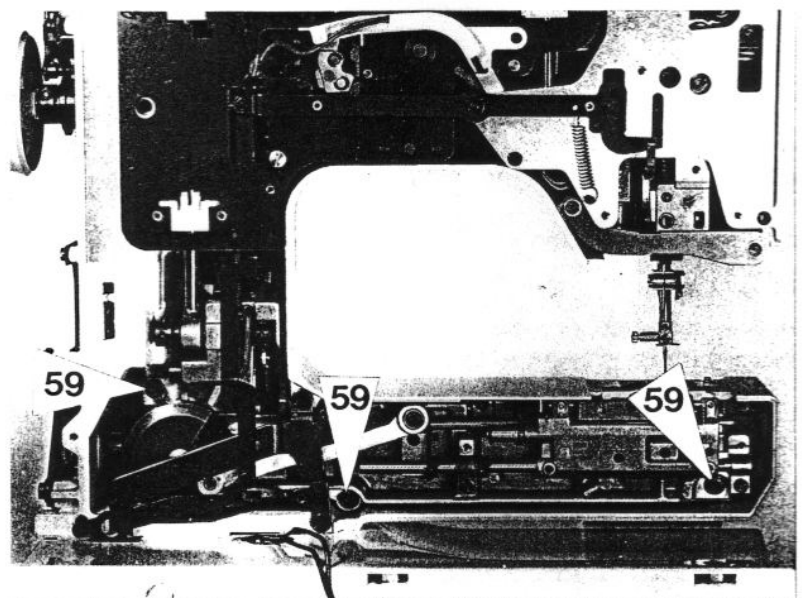
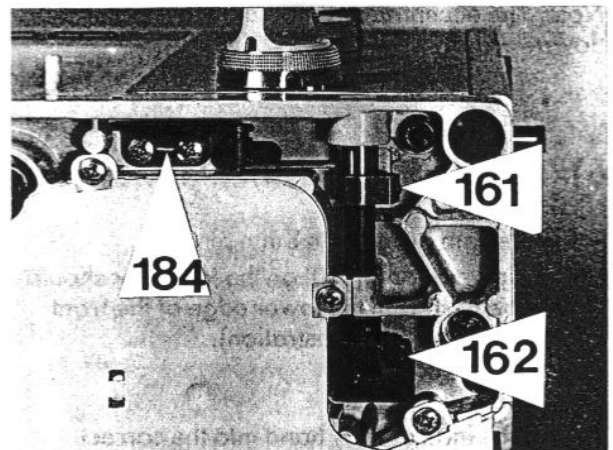
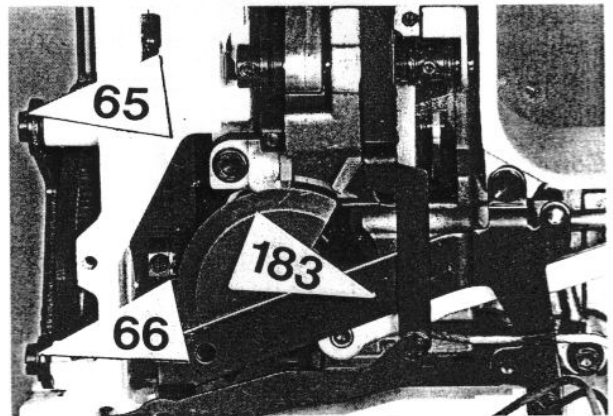

## 63 Installation of the carrier, (reverse procedure).

1. Turn the handwheel until the bore in the cam group (115) corresponds with the bore in the rigidity plate. Pin with 8 mm pin (presser foot bar).
2. Pin the needle drive balance piece and turn as far as the stop using handwheel.
3. Pin the feed operating cam (96) with 4 mm pins (38) (first hole in the direction of rotation).
4. Install the carrier complete.
5. Fit the toothed belt.
6. Screw the three allen screws (59) into the support (53).
7. Temporarily fit the stitch length adjusting knob and feed dog drop unit knob.
8. Remove the three pins.
9. Install the throat plate.
10. Position the carrier laterally in the throat plate (see section 16).
11. Adjust the feed dog height (see section 17).
12. Lower the feed dog.
13. Adjust the belt tensioner (see section 18).
14. Install the rigidity plate (183).
15. Install the feed dog drop unit lever complete; fit the 2 screws (184).
16. Install the knee lifter shaft with adjusting ring and angular lever.
17. Adjust the hook and loop lift (see section 26).
18. Check the cam timings for the feed mechanism (see section 33).
19. Adjust the lateral motion of the needle (parabola, see section 36).
20. Adjust the needle-hook distance (see section 28).
21. Install and adjust the knee lifter connecting link (see section 52/53).
22. Install stepped pulley (fit long and short drive belts).

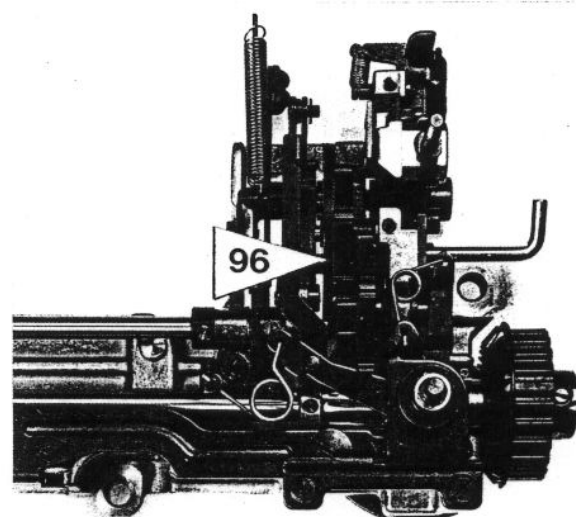
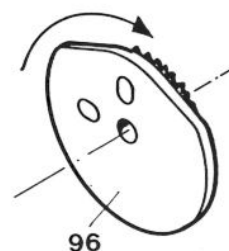
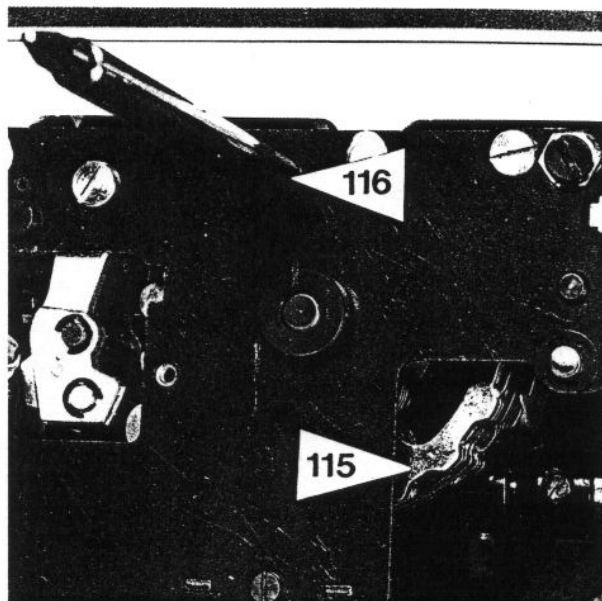



## 64 Using the special gauge for basic carrier adjustment

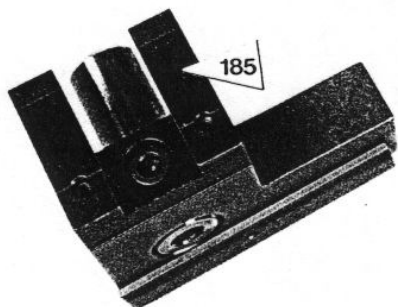

This gauge (185) is used for making the following adjustments:

1. Feed mechanism operating cam setting.
  2. Lateral positioning of the feed dog.
  3. Feed dog height.
  4. Feed dog lift and advance according to hook motion (hook drive).
- Turn the bevel gear (110) in the direction of rotation until the second bore in the feed mechanism operating cam (96) can be pinned with the 4 mm pin (38).
  - Remove the thread guide plate (103) with fixing screws and driver.

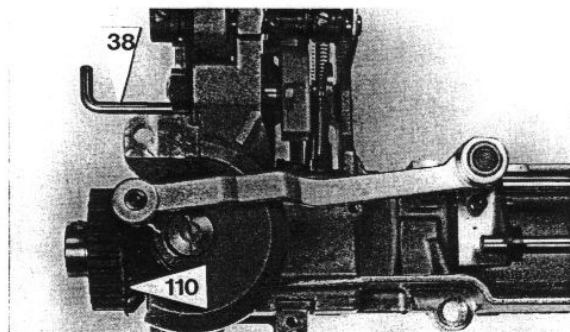

### Setting the gauge:

Squeeze the gauge together at points (186) and (187) and place it over the driver shaft. Care must be taken on the right hand side of the gauge that the angled part of the base shaft (108) is in position. At the same time the flat of the base shaft must lie cleanly on the gauge. Release points (186) and (187) (the gauge is fixed). It should no longer be possible to turn the base shaft (108).

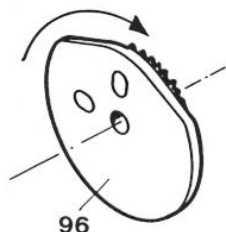
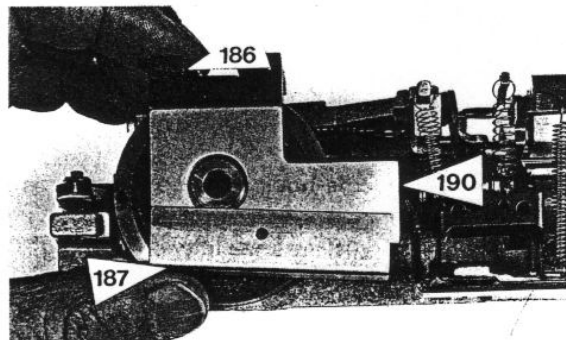

### Correction: Base shaft surface to special gauge

- Loosen the two screws (113, 114), on the toothed adjusting sleeve (183).
- Turn the intermediate wheel (189) until the second bore in the feed mechanism operating cam (96) can be pinned with 4 mm pin (38).
- Slide the gauge (185) over the drive shaft, at the same turning the base shaft until the flat (190) lies in the gauge (185).
- Tighten the screws (113, 114) on the adjusting sleeve (188). Note the axial clearance of the base shaft without the special gauge.

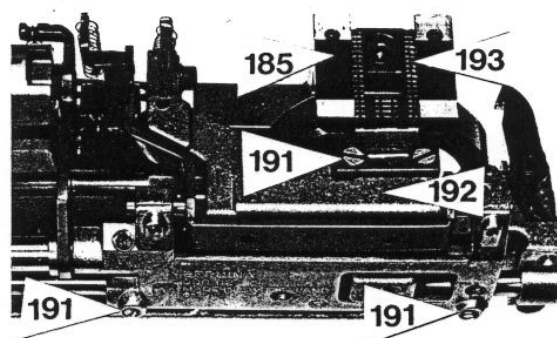
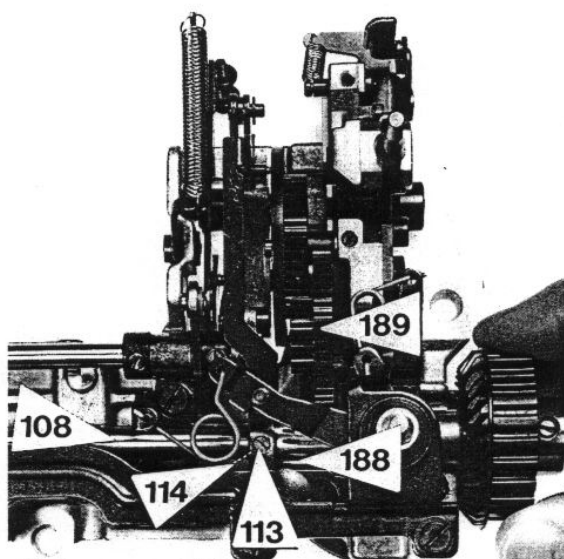

### Lateral positioning of the feed-dog

- Loosen the fixing screws (191) of the feed-dog lifter fork (192) and the feed-dog (193).
- To position the feed-dog and lifter fork, slide the feed-dog (193) into the two openings in the gauge (185).
- Tighten the four fixing screws (191).

## 65 Feed-dog height

The feed-dog height is correct when the feed-dog tips correspond with the check point on the gauge (see sketch).

### Correction of the feed-dog height

- Loosen screw (194).
- Move adjusting plate (195) of the feed-dog support accordingly.
- Tighten screw (194).

**Note:**

- If the rear feed-dog tips lie too low or too high the feed-dog height must be leveled with shims.
- Remove gauge (185).

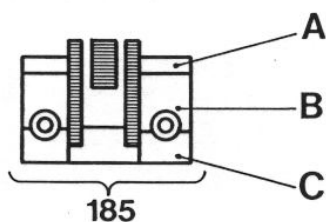
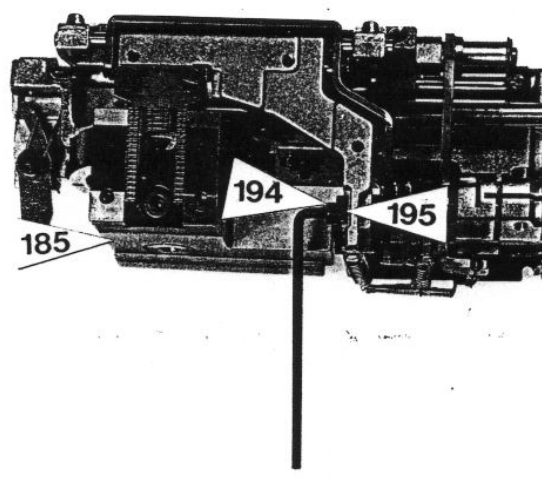

- A = Feed-dog teeth 0,1 mm higher than the gauge
- B = Feed-dog teeth flush with the gauge
- C = Feed-dog teeth should be just felt.

## 66 Checking depth limit stop

- Place feed-dog to its lowest position.
- Actuate the feed-dog drop unit. The feed-dog should now sink a further 0,1–0,2mm.

### Correction

- Adjustment to the prescribed depth is done by turning screw (186) in the feed-dog support. Check for correct operation.

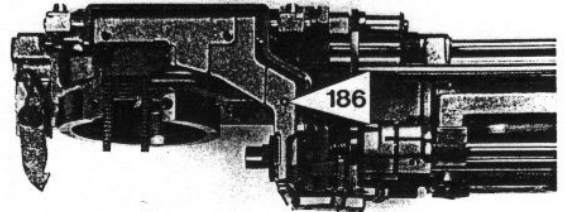

## 67 Checking the hook drive

- Slide the special gauge (185) on the drive shaft and turn the bevel gear (110) on the base shaft until the surface is correctly positioned in the gauge (185).
- The hook drive crank (94) should now correspond with the marking on the carrier (see photograph).

### Correction

- Loosen the screws on the bevel gear (110).
- Press the bevel gear (110) gently and turn it to position the hook drive crank (94).
- Tighten the bevel gear screws.

### Check

Remove the special gauge (185) and turn the bevel gear to check that its teeth mesh properly and that the base shaft has the correct axial clearance.

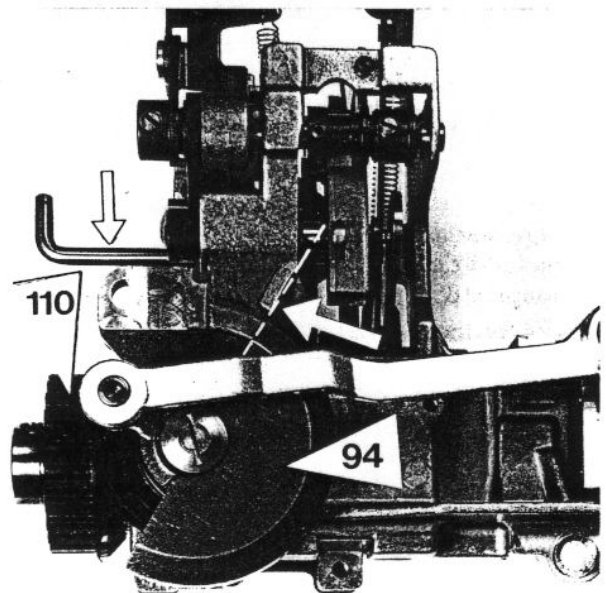

## 68 Checking the axial play in the stitch length crank

- Insert a 0,15 mm feeler gauge between the stitch length crank (135) and the block (197). The feeler gauge should have a sliding fit.

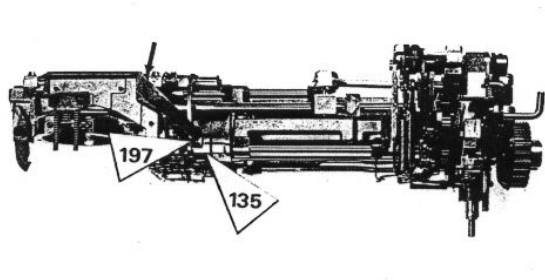

### Correction

- Loosen the setting collars (198) and (199) on the length crank shaft (135).
- Insert a 0,15 mm feeler gauge between the block (197) and the stitch length crank (135).
- Move the stitch length crank shaft to the left as far as the stop.
- Tighten the setting collar (198).
- Set the setting collar (199) on the connecting bracket (200) so that it has no clearance but does not jam.
- Tighten the screws (199).

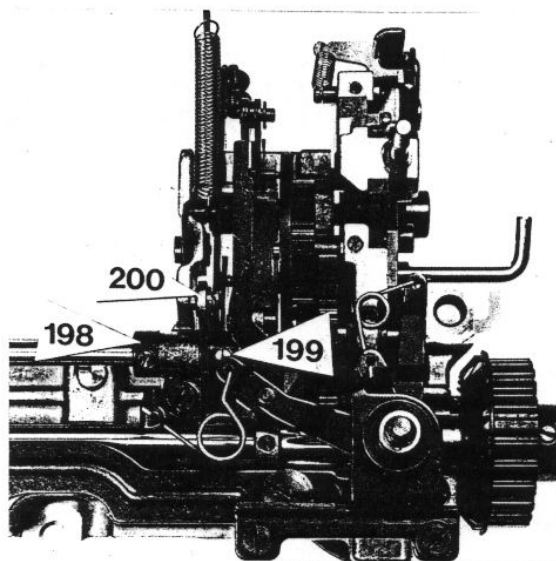

## 69 Checking the zero position of the stitch length crank

- Screw the stitch length adjusting lever in as far as the stop.
- When the base shaft (110) is turned the feed advance fork (192) should not perform any feed movement.

### Correction

- Loosen the 2,5 mm allen screw (136).
- Press the crank (135) to the right against the stop.
- Turn the bevel gear (110) by hand and adjust the crank (135) until the advance fork (192) no longer makes any motion.
- Tighten the allen screw (136).

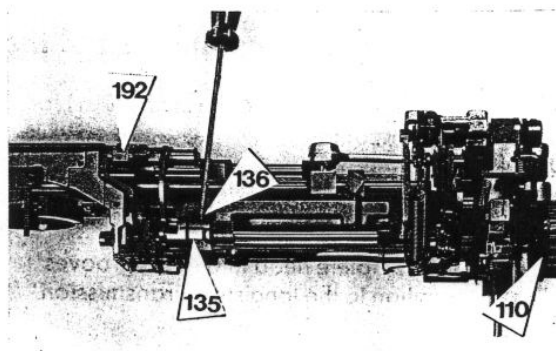

## 70 Removal of head frame

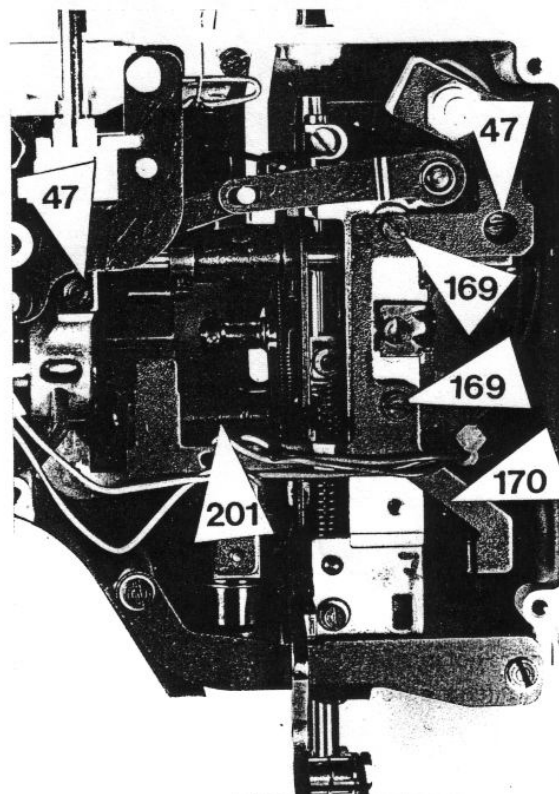
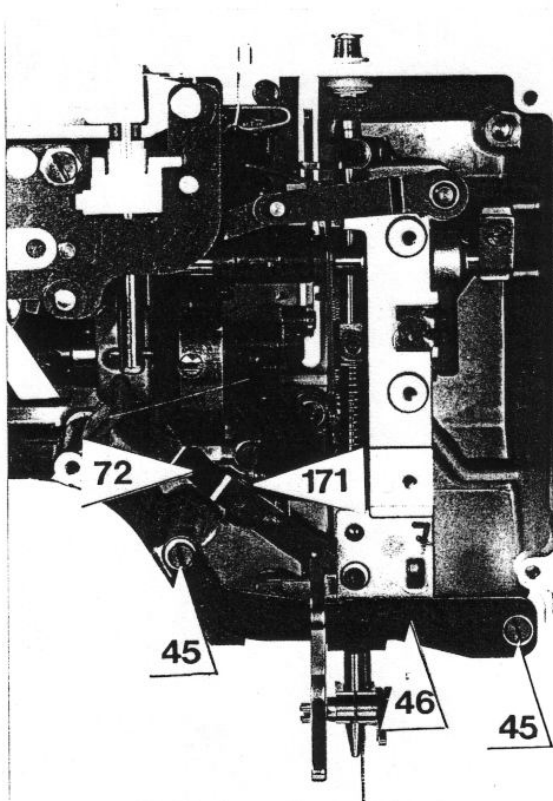

- Remove the presser foot and needle.
- Remove the rigidity plate (44).
- Remove the 2 screws (169).
- Remove the complete lamp mounting (170).

### Separate connecting strap from needle bar support

- Using a screwdriver turn the flat spring (171) at the back of the connecting strap (72) until the ball and socket connection is released.

- Raise connecting strap (72). *Caution:* The ball may fall out.
- Remove both screws (45) from the fixing bracket (46) on the head frame.
- Remove the fixing screws with clamps (47).
- Turn the handwheel and set the needle bar link (201) towards the rear (horizontal).
- Remove the head frame to the rear, then remove the needle bar carrier and thread take-up lever to the right.

## 71 Sequence for installation of the head frame

1. Rotate the handwheel and the crank (201) to the rear (horizontal).
2. Lower the material presser bar.
3. Attach the needle bar carrier and thread take-up lever.
4. Insert the complete head into the V-grooves (pay attention to the long stitch transmission lever).
5. a) Fit the 2 screws with clamp (47) and tighten provisionally.  
b) Fit the 2 screws (45) on the fixing bracket (46) and tighten provisionally.
6. Insert the ball and close the connecting strap connection (171).
7. Fit the lamp mounting complete.
8. Carry out the necessary adjustments (see section 72).

## 72 Notes on adjustments to be made after removing and reinstalling certain parts

### Rigidity plate

1. Needle – hook distance (see section 28).
2. Throat plate position (see section 30).

### Head frame

1. Presser foot fixing and height (sections 11/12).
2. Darning foot height (section 13).
3. Position of presser foot, crosswise to sewing direction (section 14).
4. Lateral distribution of thread take-up lever (see section 15).
5. Rest position of needle (section 20).
6. Lateral needle distribution L.C.R. (section 21).
7. Zig-zag stitch distribution (section 35).
8. Cutting space and bead width for buttonholing foot (section 46).
9. Fitting the rigidity plate with knee lifter (sections 52/53).
10. Needle – hook distance (section 28).
11. Throat plate adjustment (section 30).

### Carrier

1. Lateral position of feed-dog in the throat plate (section 16).
2. Height of feed-dog (section 17).
3. Tension of the hook drive belt (section 18).
4. Lateral needle distribution L.C.R. (section 21)
5. Hook adjustment – loop lift (section 26).
6. Needle height (section 27).
7. Needle – hook distance (section 28).
8. Thread guide plate (section 29).
9. Throat plate adjustment (section 30).
10. Cam timings for feed mechanism and upper shaft (section 33).

### Needle control drive assembly

1. Presser foot fixing and height (sections 11/12).
2. Darning foot height (sections 13).
3. Position of presser foot, crosswise to sewing direction (section 14).
4. Lateral distribution of thread take-up lever (see section 15).
5. Attaching the automatic buttonholer (section 57).
6. Rest position of needle (section 20).
7. Lateral needle distribution L.C.R. (section 21).
8. Removing the throat plate (section 6).

9. Needle – hook tip distance (section 26: pinning the feed operating cam and balance piece).
10. Installing the throat plate.
11. Zig-zag stitch distribution (section 35).
12. Lateral motion of needle (arc, section 36).
13. Installing the cable ducts.
14. Installing the reinforcement plate (4 screws, 1 circlip).
15. Needle – hook distance (section 28).
16. Needle stop (section 47).

### Buttonhole Automatic

1. Pin automatic with 4 mm pin.
2. Stitch length knob (section 39).
3. Stitch distribution L.C.R. (section 21).
4. Stitch distribution zig-zag (section 35).
5. Cutting space and bead widths (section 46).



# Notes:

## 73 Electrical and electronic section

### Description

The entire electronics of models 1030/1020 are incorporated in a single module. In case of defects this module is replaced complete.

**The motor controls** for the main drive motor operate on rectified mains voltage converted into DC pulsating voltage. The familiar advantages of the DC motor already employed in models 930 and 1130 are as follows:

- High efficiency
- Improved speed regulation
- High torque at low speeds

**The electronic motor controls** keep the speed selected with the foot pedal constant independently of the load. If the drive mechanism is blocked the motor is switched off automatically after 4,4 seconds.

**The needle stop mechanism** is triggered by a light barrier independent of the speed. By eliminating R35 from print L 1030, the needle stops in the lowest position instead of the highest position when the foot pedal is released.

**The bobbin winder motor and sewing light** are powered at a safe low voltage of 6 V.

## 73.0 Print L/R 1030/1020 220V

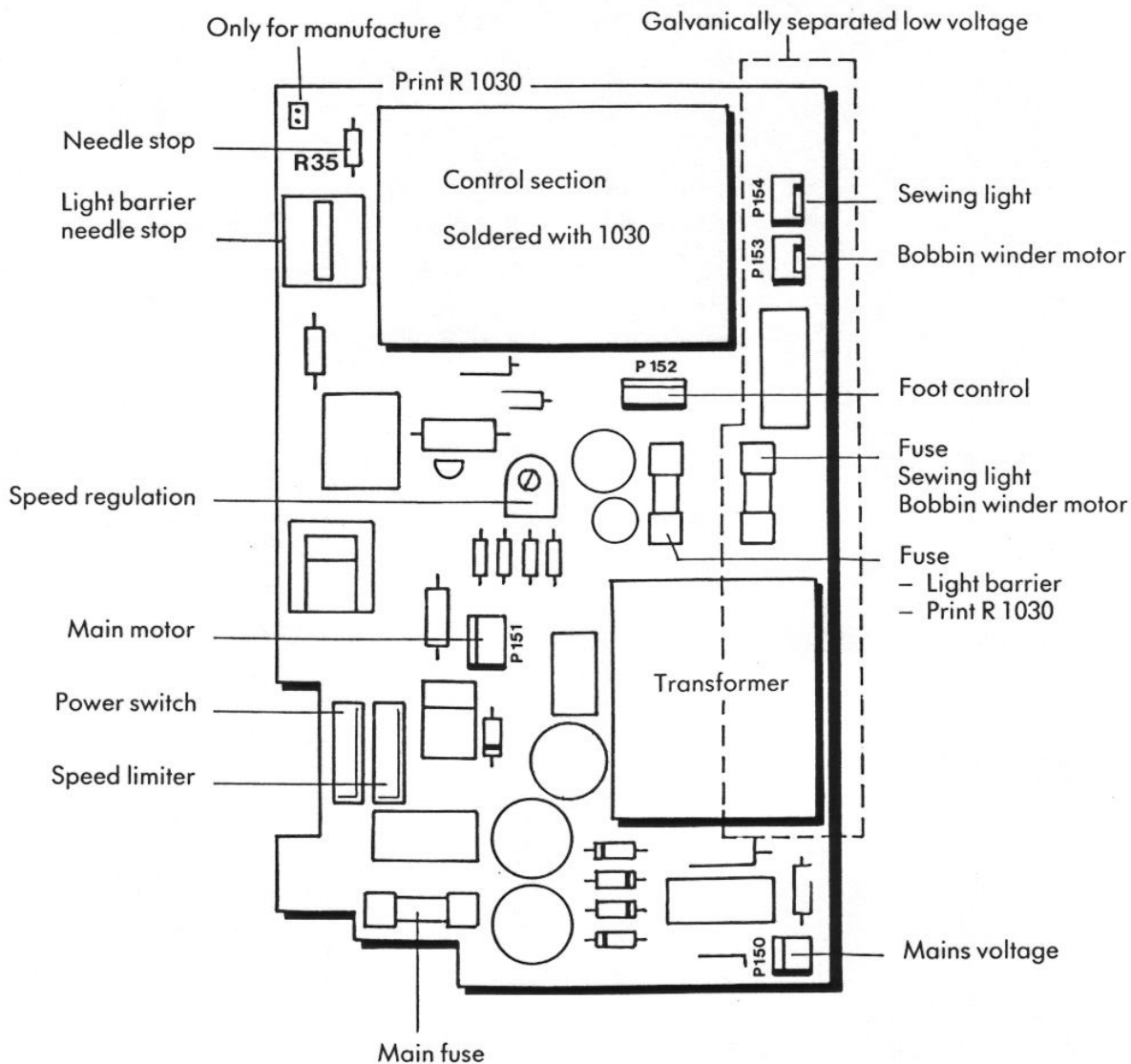

**Warning!**

The entire print, with the exception of the separate low voltage section, operates at dangerous voltages. See notes on page 4.



## 73.1 Print L/R 1030/1020 110V

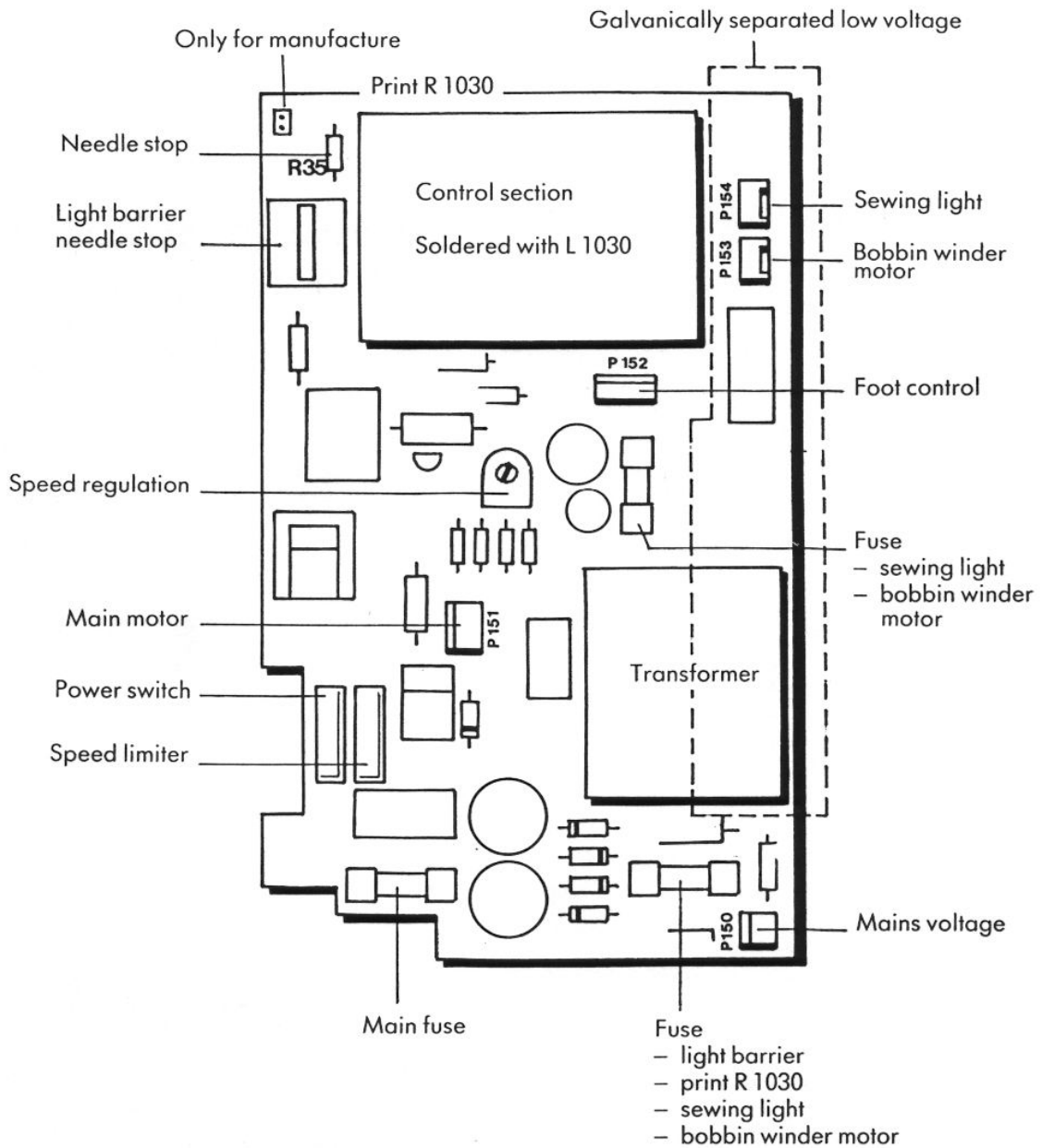

**Warning!**

The entire print, with the exception of the separate low voltage section, operates at dangerous voltages. See notes on page 4.



## 73.2 Print L/R 1030/1020

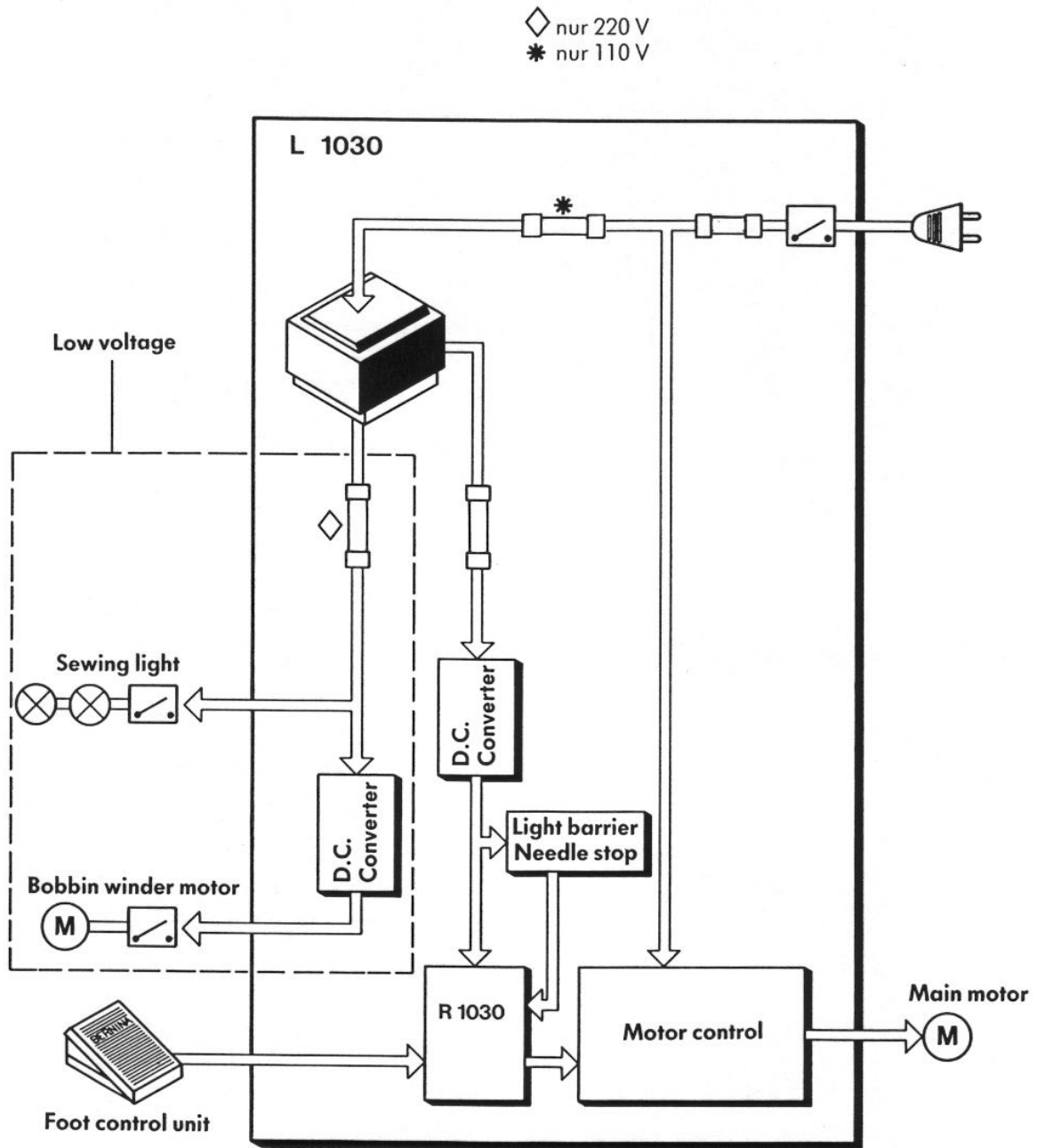

**dangerous voltage**

**Warning!**

The entire print, with the exception of the separate low voltage section, operates at dangerous voltages. See notes on page 4.

Description

## 74.0 Guide for trouble-shooting

### Repair procedure

Since the entire electronics are compactly arranged on a single module, it is usually best to replace the entire print in the event of faults. The L and R prints are soldered together. It is not possible to repair the R print, which is therefore replaced completely. Correct replacement of the R print requires expert soldering knowledge!



### Mains voltage (see print L/R 1030)

The circuits on print L/R 1030, the main drive motor, cable drum and foot control carry dangerous voltages!

Since some of the condensers take about 30 seconds to discharge after the main power supply plug has been disconnected, take care not to touch any parts of the circuit carrying dangerous voltages during this time.

The sewing machine should only be connected to the power supply when the chassis cover or auxiliary cover is fitted.

No work should be carried out on the L/R print, main drive motor, cable drum or foot control until the main power supply plug has been disconnected.



Warning – dangerous voltages!

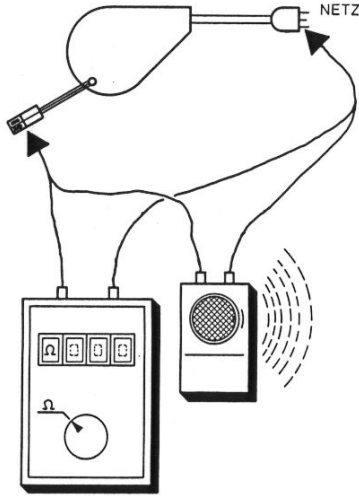

Symptom	Possible fault in	Repair instructions
Sewing light does not light up, bobbin winder and main drive motor do not operate	<ul style="list-style-type: none"> <li>- No power supply</li> <li>- Power cable</li> <li>- Print L/R 1030</li> </ul>	<ul style="list-style-type: none"> <li>- Test ❶</li> <li>- Test ❷</li> </ul>
Main drive motor does not operate. Sewing light and bobbin winder operate.	<ul style="list-style-type: none"> <li>- Main motor</li> <li>- Foot control unit</li> <li>- Connection print L/R</li> <li>- To foot control</li> <li>- Print L/R</li> </ul>	<ul style="list-style-type: none"> <li>- Test ❷</li> <li>- Test ❹ Replace foot control</li> <li>- Test ❸</li> <li>- Test ❷</li> </ul>
Bobbin winder motor does not operate.	<ul style="list-style-type: none"> <li>- Bobbin winder motor</li> <li>- Print L/R</li> </ul>	<ul style="list-style-type: none"> <li>- Test ❷</li> <li>- Test ❷ Fuse F 147</li> </ul>
Sewing light does not operate	<ul style="list-style-type: none"> <li>- Lamp bulb</li> <li>- Lamp mounting with switch</li> <li>- Print L/R</li> </ul>	<ul style="list-style-type: none"> <li>- change</li> <li>- Test ❸</li> <li>- Test ❷ Fuse F 147</li> </ul>
Needle does not stop at top or bottom, but in any position.	<ul style="list-style-type: none"> <li>- Print L/R</li> </ul>	<ul style="list-style-type: none"> <li>- Print L/R replace</li> </ul>
Main motor blocked, does not switch off after 4,4 seconds.	<ul style="list-style-type: none"> <li>- Print L/R</li> </ul>	<ul style="list-style-type: none"> <li>- Print L/R replace</li> </ul>

What is to be tested	What to adjust	Normal condition
<p>Mains cord (cord reel)</p>	<ul style="list-style-type: none"> <li>- Take out mains plug.</li> <li>a) Disconnect mains plug at P150 on print L1030.</li> <li>b) Connect one end of the tester to the plug, then test every wire to check that a circuit can be made.</li> </ul>	<div style="text-align: right;">  </div> <ul style="list-style-type: none"> <li>- High pitched tone! Cord ok.</li> <li>- Ohmmeter shows a small resistance, cord ok.</li> </ul>

**Important:**

If there is no high pitched tone, or the display of the ohmmeter wavers or shows infinite resistance, then the cord is defective. Replace cord reel.

**Test ❶**

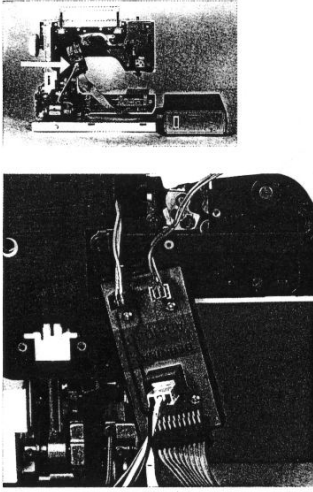
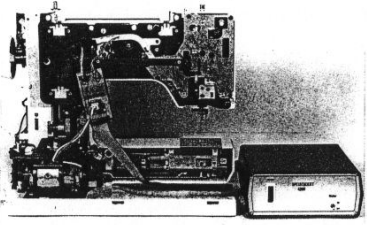
What is to be tested	What to adjust	Normal condition
<p>Sewing light Winder motor Main motor Print L-1030</p>	<p>Mains switch off</p> <ul style="list-style-type: none"> <li>- Connect mains adaptor to sewing light, bobbin winder motor and main motor.</li> <li>- Turn on mains adaptor.</li> </ul> 	 <p>Winder motor, sewing light and main motor operate</p>
<ul style="list-style-type: none"> <li>- Sewing light does not light up. Replace light bulb or lamp mounting complete.</li> <li>- Bobbin winder does not operate replace motor.</li> <li>- Main motor does not work replace main motor.</li> </ul>	<p><i>Important:</i> The bobbin winder motor, sewing lamp and main motor operate with the adaptor but not with the L1030 print. Replace L1030 print.</p>	

**Test ②**

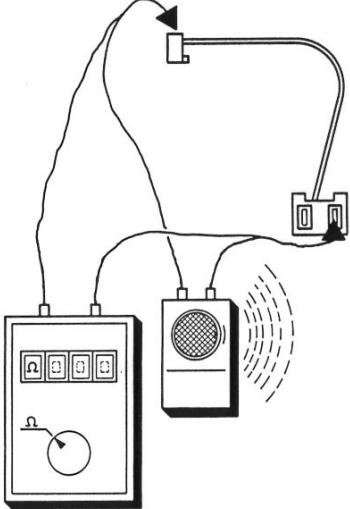
What is to be tested	What to adjust	Normal condition
<p>Connection of print L-1030 to foot control plug.</p>	<ul style="list-style-type: none"> <li>- Take out mains plug.</li> <li>a) Remove 2 pin white, foot control plug from print L-1030.</li> <li>b) On the upper connection side of the print check with the circuit maker or ohmmeter that a circuit can be made between these and the foot control plug.</li> <li>c) Both connections on foot control plug have to be tested as described above.</li> </ul>	<div style="text-align: center;">  </div> <ul style="list-style-type: none"> <li>- High pitched tone! Cord ok.</li> <li>- Ohmmeter shows a small resistance, cord ok.</li> </ul>

*Important:*  
 If there is no high pitched tone, or the display of the ohmmeter wavers or shows infinite resistance, then the cord is defective. Replace cord.

**Test ③**

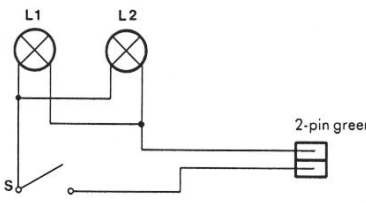

What is to be tested	What to adjust	Normal condition
Lamp holder	<ul style="list-style-type: none"> <li>- Mains switch on.</li> <li>a) Switch on sewing light.</li> </ul>	<ul style="list-style-type: none"> <li>- Sewing light burns.</li> </ul>  <p>The diagram shows a circuit with two lamps, L1 and L2, connected in parallel. A switch, labeled 'S', is connected in series with the parallel combination of the lamps. The circuit is connected to a 2-pin green plug. The wiring is as follows: one terminal of the plug connects to the switch, which then connects to both L1 and L2. The other terminal of the plug connects to the other side of both L1 and L2.</p>

**Important:**

If the sewing light doesn't function and both bulbs are intact, then the connections from L1, L2 and S to the plug can be checked with the circuit tester or ohmmeter.

The switch can be checked with the following method. Place test device leads in the plug (2-pin green), by switching on and off, the device must register continuity or high resistance (blockage).

**Test 6**



What is to be tested	Normal condition
Main motor Set mains switch to 1 Fully depress foot control	Machine operates at 1050 S.p.m.
Main motor Set mains switch to ½ Fully depress foot control	Machine operates at 600 S.p.m.
For the following tests set the main switch to 1	
Switch on bobbin winder motor Switch off bobbin winder motor	Bobbin winder motor runs  Bobbin winder motor stops
Switch on sewing light  Switch off sewing light	Sewing light comes on  Sewing light goes out
Main motor  Fully depress foot control  Stop from fastest speed  Press foot control backwards	Motor stops, thread take-up lever is in its highest position  Machine goes to lowest needle position

Electrical/Electronic test